

**NEW  
PRODUCT!**

# ASM90-S012

## Square Shoulder Milling



## • ASM90-SO12 Series Product Introduction

ASM90-SO12 Achteck's shoulder milling cutters combined with inserts that feature a self-developed next-generation substrate and coating are suitable for steel, cast iron and stainless steel, providing a complete solution for shoulder milling.

### Features

- Precision 90° and economical.
- Double clearance angle and spiral edge design to reduce cutting forces.
- Manufactured with a short wiper to obtain a good surface finish.
- Multiple connection types: cylindrical shank, weldon shank and arbor mount.

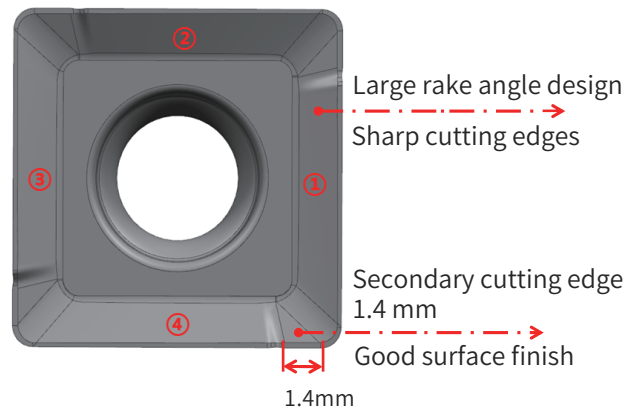
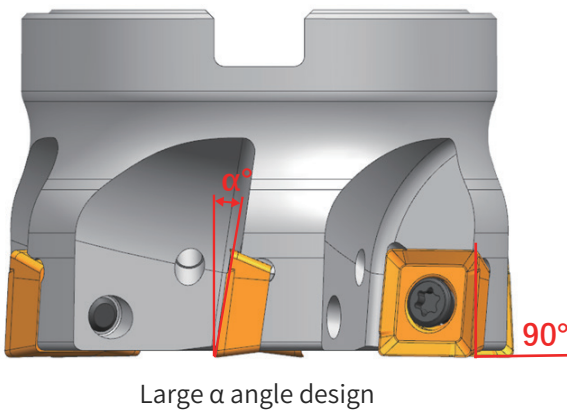
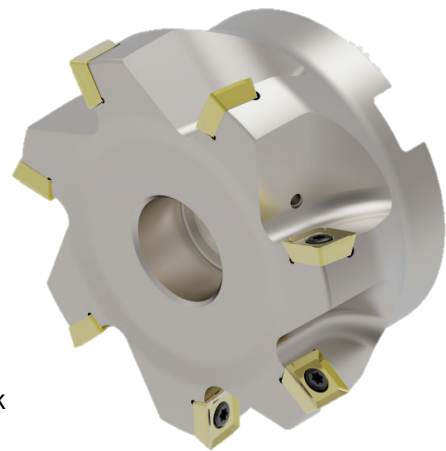

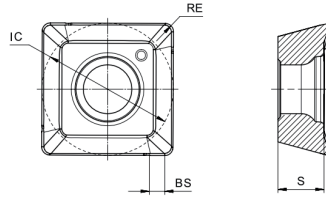
**◆ SOMT 1204.. Insert**

Insert code	Dimension				Grade						
	IC	S	RE	BS	P		M		K		S
					AP251U	AC251P	AP351M	AP403M	AP251K	AC151K	AP403S
SOMT 120408PDER-MM4	12.46	4.8	0.8	1.35	●	●	●	●	●	●	●

● Stock available

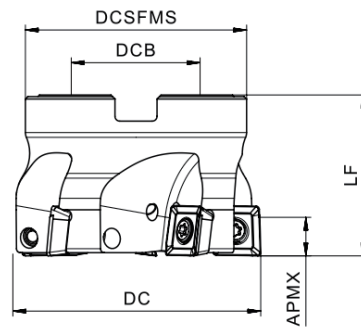
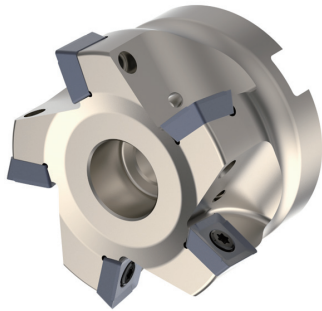
**◆ ASM90-SO12 Cutter**

Cutter code	DC	DCB	LF	DCSFMS	APMX	Internal coolant	Z	Insert code
ASM90-050-Z04-A22R-SO12-C	50	22	40	45	10		4	SOMT 1204..
ASM90-050-Z05-A22R-SO12-C	50	22	40	45	10		5	
ASM90-063-Z05-A22R-SO12-C	63	22	40	55	10		5	
ASM90-063-Z06-A22R-SO12-C	63	22	40	55	10		6	
ASM90-080-Z06-A27R-SO12-C	80	27	50	62	10		6	
ASM90-080-Z08-A27R-SO12-C	80	27	50	62	10		8	
ASM90-100-Z05-A32R-SO12-C	100	32	50	80	10		5	
ASM90-100-Z07-A32R-SO12-C	100	32	50	80	10		7	
ASM90-100-Z10-A32R-SO12-C	100	32	50	80	10		10	
ASM90-125-Z08-A40R-SO12-C	125	40	63	90	10		8	
ASM90-125-Z12-A40R-SO12-C	125	40	63	90	10		12	
ASM90-160-Z12-A40R-SO12	160	40	63	107	10		12	
ASM90-160-Z15-A40R-SO12	160	40	63	107	10		15	
ASM90-200-Z16-A60R-SO12	200	60	63	130	10		16	
ASM90-250-Z18-A60R-SO12	250	60	63	180	10		18	

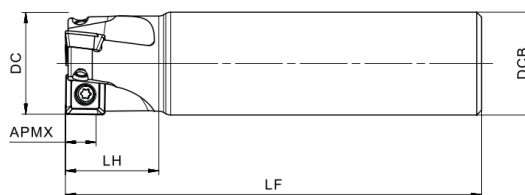
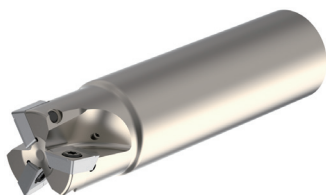
**◆ ASM90-SO12 Cutter**

Cutter code	DC	DCB	LF	LH	APMX	Internal coolant	Z	Insert code
ASM90-032-Z02-C25R-SO12-L100-C	32	25	100	34	10		2	SOMT 1204..
ASM90-032-Z03-C32R-SO12-L130-C	32	32	130	30	10		3	
ASM90-040-Z03-C32R-SO12-L170-C	40	32	170	35	10		3	
ASM90-050-Z03-C32R-SO12-L120-C	50	32	120	35	10		3	
ASM90-050-Z04-C32R-SO12-L120-C	50	32	120	35	10		4	

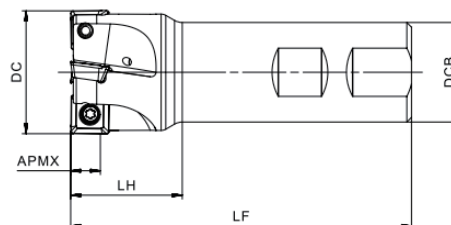
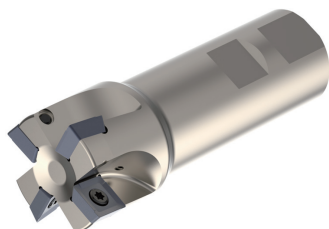

Cutter code	DC	DCB	LF	LH	APMX	Internal coolant	Z	Insert code
ASM90-032-Z03-W32R-SO12-L130-C	32	32	130	34	10		3	SOMT 1204..
ASM90-040-Z04-W32R-SO12-L110-C	40	32	110	30	10		4	

Dimension (mm)	Spare parts		
Cutter diameter	Screw	Wrench	Torque
φ32-250	SP040112	DT-TP15	3.5Nm



◆ **ASM90-SO12 Success Story**

Workpiece: Turbocharger Housing  
Material: 1.4826  
Insert: SOMT 120408PDER-MM4 AP351M  
Cutter: ASM90-032-Z03-C32R-SO12-L130-C  
Machining: Cutting cavity  
Cutting Data: Vc=109m/min, ap=6mm, fz=0.015mm  
Coolant: Wet



Story resource: End user

◆ **ASM90-SO12 Success Story**

Workpiece: Arm Bracket  
Material: High-strength Steel  
Insert: SOMT 120408PDER-MM4 AP351M  
Cutter: ASM90-100-Z07-A32R-SO12-C  
Machining: Face milling  
Cutting Data: Vc=157m/min, ap=5mm, fz=0.12mm  
Coolant: Dry

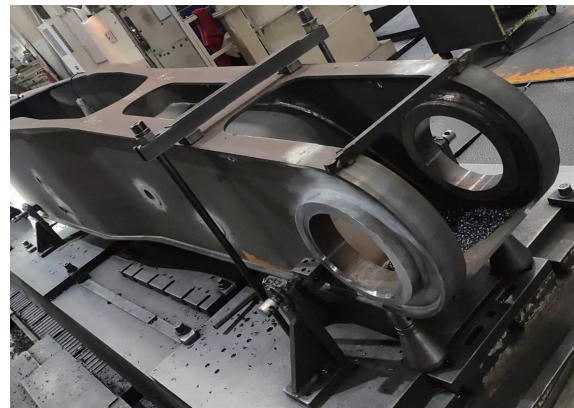

Story resource: End user