

NEW
PRODUCT!

AT202 Cermet inserts

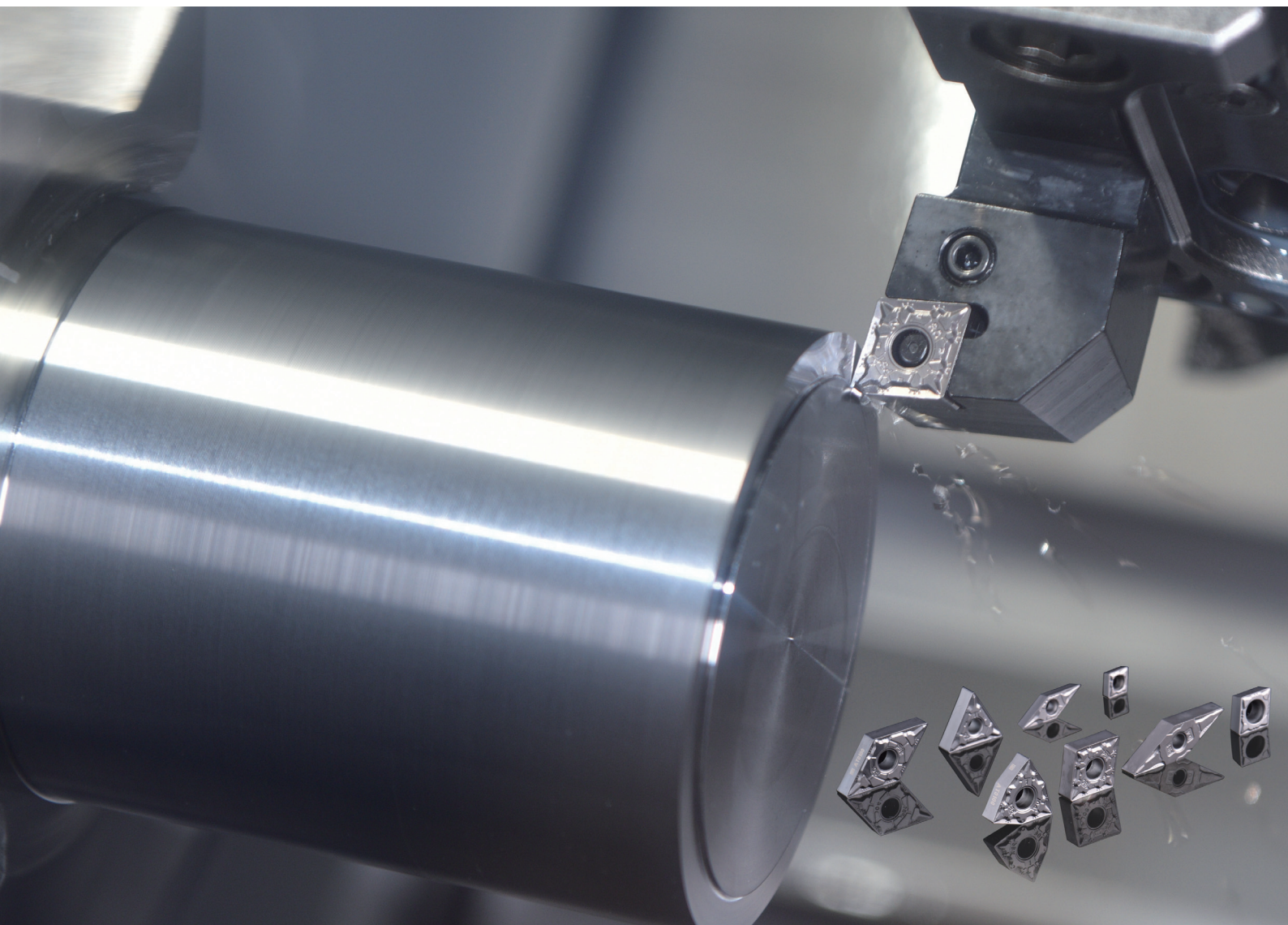

New Turning Cermet Inserts

Wide application range, offer strong toughness and longer tool life

Features

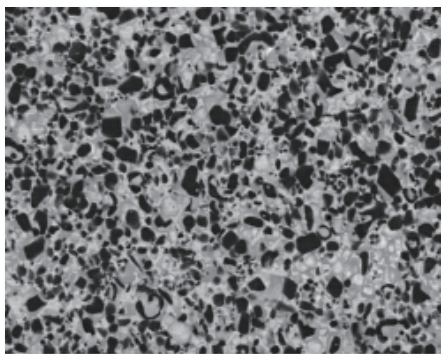

High stability

The hot hardness and thermal shock resistance are greatly improved through the cladding of fine grain hard particles and multi-component poly-crystal carbides. Therefore, stable tool life can be obtained under severe cutting conditions.

Excellent cutting performance

The special enhancement technologies are adopted, greatly improve the binding force which guarantee the excellent edge chipping and wear resistance, high-quality finishing surfaces.

Benefit:

- General purpose AT202 steel processing 1st recommendation;
- Excellent wear resistance, high-efficiency machining and high-quality finishing surface;
- Longer tool life and higher productivity in comparison to carbide;
- Reflective surfaces at high and low cutting speeds;

Application range and cutting conditons

Machining materials	Steel (Carbon steel / Alloy steel)					Cast iron				
	Finishing Machining ← → Rough Machining					Finishing Machining ← → Rough Machining				
ISO classification	P01	P10	P20	P30	P40	K01	K10	K20	K30	K40
Cermet		AT200					AT200			
		AT202 NEW					AT202 NEW			

Workpiece materials		Hardness	Cutting speed (m/min)
P	CARBON STEELS 1018, 1040, 1080, 1090.....	HB ≤ 180	150-300
	ALLOY STEELS 4140, 4150, 4320.....	HB ≥ 180	120-260

◆ **Wear resistance comparison**

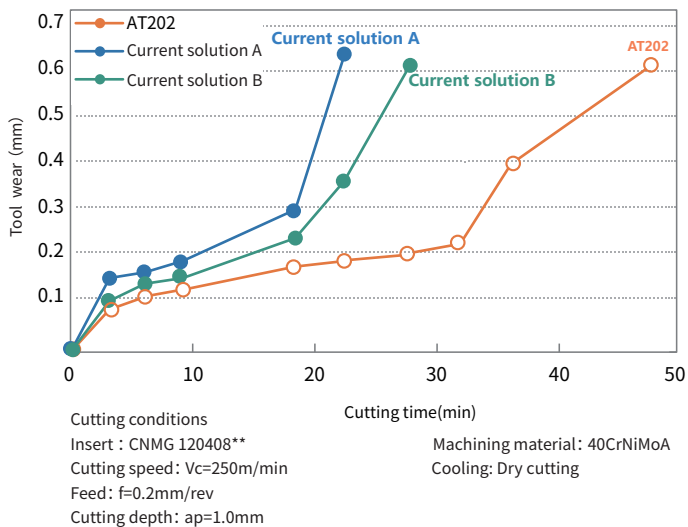

Cutting time 18.4 minutes comparison

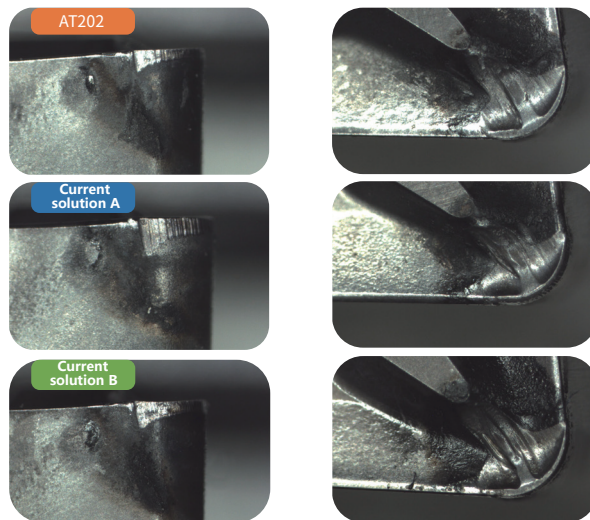

◆ **Edge breakage comparison**

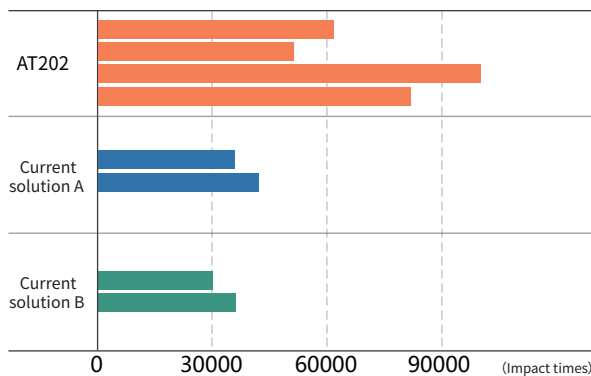
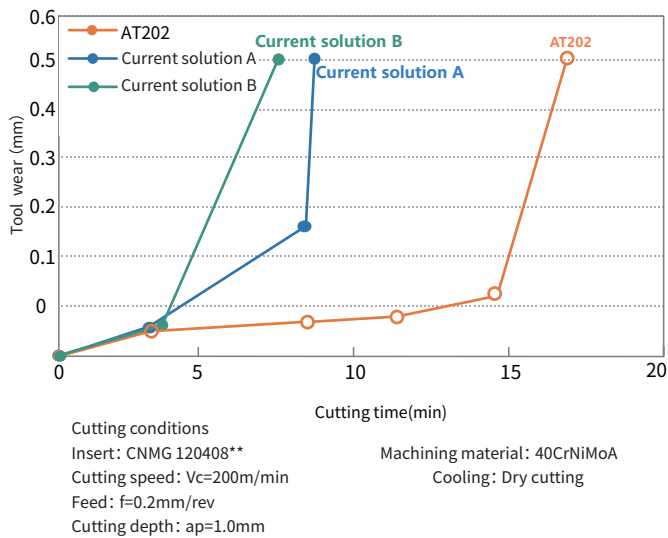

◆ **Grade and application range**

	Continuous machining	general machining	light interrupt machining
Steel	<div style="background-color: #4a86e8; color: white; padding: 5px; text-align: center;">AT200</div> <div style="background-color: #e69d00; color: white; padding: 5px; text-align: center;">AT202</div>		

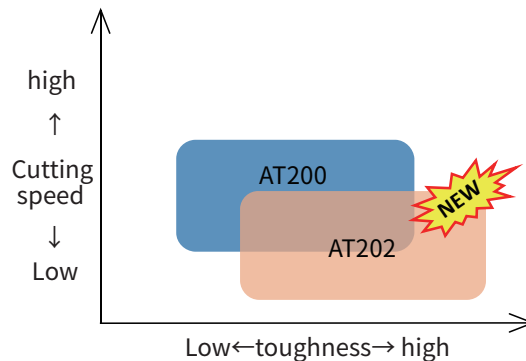

Chip breakers - Negative

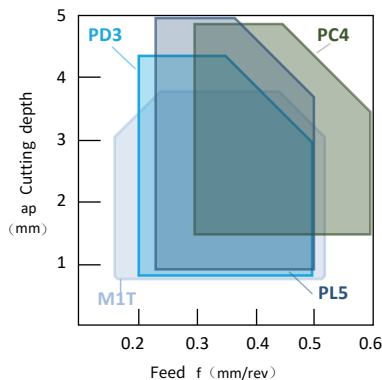
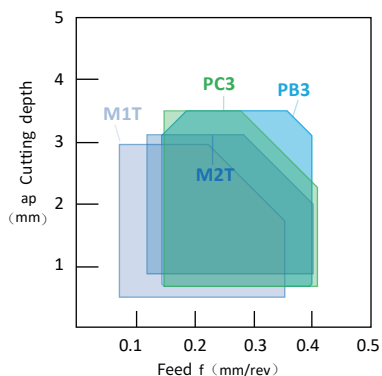
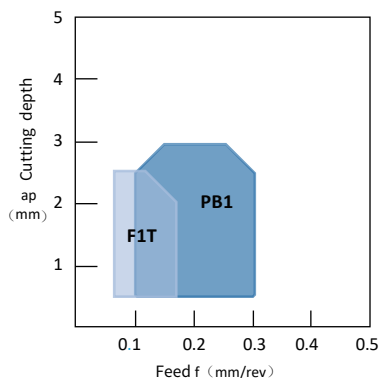

Application	Chipbreaker	Features	Cross section of the chipbreakers
Finishing machining	F1T	Finish machining. Very good chip control at small cutting depth.	
	PB1	General purpose finish geometry. Good stability.	
Semi-finishing machining	M1T	Big positive rake angle, low cutting force, suitable for different cutting depth.	
	PB3	First choice for steel semi-finishing turning, can be used in profile turning with different cutting depth, and offer excellent chip control.	
	M2T	Designed for low cutting force, combined strengthened cutting edge. Suitable for medium turning with big cutting depth.	
Medium machining	PC3	2 nd choice for steel semi-finish turning.	
	PD3	Guaranteed stability, stronger cutting edge can be used in interrupt turning.	
	M3T	Smooth rake surface, suitable for medium turning with big feed rate.	
	PC4	Reduced cutting force, suitable for steel and cast iron general purpose machining.	
	PL5	Suitable for medium machining with low cutting force, big cutting depth. Suitable for long shaft turning.	
Profiling	BS	Suitable for profile turning with changing cutting depth. Smooth chip evacuation.	

Chip breakers - Positive

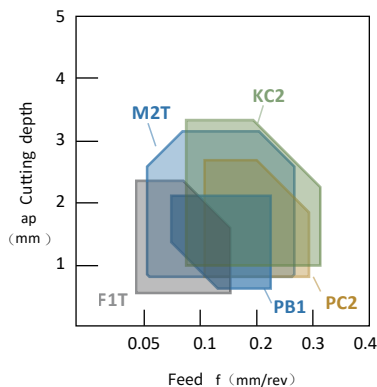

Application	Chipbreaker	Features	Cross section of the chipbreakers
Finishing machining	F1T	Low cutting force, excellent chip control	
	PB1	General purpose geometry for finish machining with good stability.	
Semi-finishing machining	PC2	1 st choice for semi-finish turning. Good edge strength and chip control.	
	M2T	Designed for high feed turning with smooth chip evacuation.	
	KC2	Big chip breaker design, suitable for machining with big cutting depth.	

● Case study

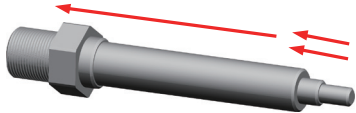
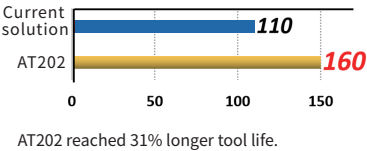
Insert	TNMG 160404R-M1T AT202
Workpiece	Connecting Bar parts 
Machining materials	45#
Cutting speed	180m/min
Feed	0.31mm/rev
Cutting depth	1.50mm
Cooling	Water Soluble Emulsion
Result	 <p>AT202 reached 31% longer tool life.</p>

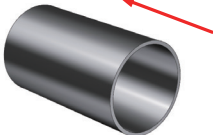
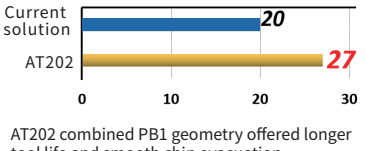

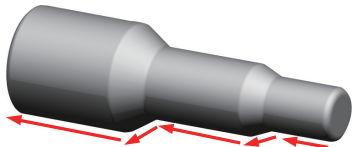
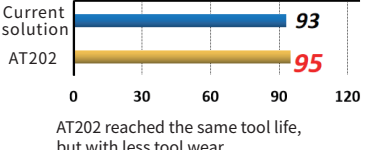

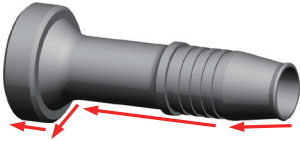
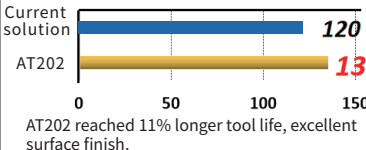

Insert	TNMG 160404E-PB1 AT202
Workpiece	Hydraulic Pipe Fitting parts 
Machining materials	45#
Cutting speed	400m/min
Feed	0.10mm/rev
Cutting depth	0.20mm
Cooling	Water Soluble Emulsion
Result	 <p>AT202 combined PB1 geometry offered longer tool life and smooth chip evacuation.</p>

Insert	TNMG 160404E-PB1 AT202
Workpiece	Shaft sleeve parts 
Machining materials	20CrMo (Tempered)
Cutting speed	94m/min
Feed	0.20mm/rev
Cutting depth	0.20mm
Cooling	Water Soluble Emulsion
Result	 <p>AT202 reached the same tool life, but with less tool wear.</p>





Insert	VNMG160404E-M3T AT202
Workpiece	Hydraulic Pipe Fitting parts 
Machining materials	35#, 45#
Cutting speed	160m/min
Feed	0.16mm/rev
Cutting depth	0.70mm
Cooling	Water Soluble Emulsion
Result	 <p>AT202 reached 11% longer tool life, excellent surface finish.</p>







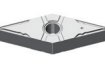
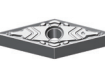

● Product list

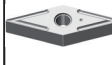
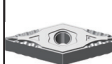
Insert	Product code	Dimension(mm)				Grade
		d	s	d1	r	AT202
	CNMG 120404E-PB1	12.7	4.76	5.16	0.4	●
	120408E-PB1	12.7	4.76	5.16	0.8	●
	CNMG 120404E-PB3	12.7	4.76	5.16	0.4	●
	120408E-PB3	12.7	4.76	5.16	0.8	●
	120412E-PB3	12.7	4.76	5.16	1.2	●
	CNMG 120404E-PC3	12.7	4.76	5.16	0.4	●
	120408E-PC3	12.7	4.76	5.16	0.8	●
	120412E-PC3	12.7	4.76	5.16	1.2	●
	CNMG 120404E-PD3	12.7	4.76	5.16	0.4	●
	120408E-PD3	12.7	4.76	5.16	0.8	●
	120412E-PD3	12.7	4.76	5.16	1.2	●
	DNMG 110404E-PB1	9.525	4.76	3.81	0.4	●
	150404E-PB1	12.7	4.76	5.16	0.4	●
	150408E-PB1	12.7	4.76	5.16	0.8	●
	150604E-PB1	12.7	6.35	5.16	0.4	●
	150608E-PB1	12.7	6.35	5.16	0.8	●
	DNMG 150404E-PB3	12.7	4.76	5.16	0.4	●
	150408E-PB3	12.7	4.76	5.16	0.8	●
	150412E-PB3	12.7	4.76	5.16	1.2	●
	150604E-PB3	12.7	6.35	5.16	0.4	●
	150608E-PB3	12.7	6.35	5.16	0.8	●
	150612E-PB3	12.7	6.35	5.16	1.2	●
	DNMG 150404R-M1T	12.7	4.76	5.16	0.4	●
	150404L-M1T	12.7	4.76	5.16	0.4	●
	150404E-PC3	12.7	4.76	5.16	0.4	●
	150408E-PC3	12.7	4.76	5.16	0.8	●
	150412E-PC3	12.7	4.76	5.16	1.2	●
	150604E-PC3	12.7	6.35	5.16	0.4	●
	150608E-PC3	12.7	6.35	5.16	0.8	●
	150612E-PC3	12.7	6.35	5.16	1.2	●

Insert	Product code	Dimension(mm)				Grade
		d	s	d1	r	AT202
	DNMG 110404E-PD3	9.525	4.76	3.81	0.4	●
	110408E-PD3	9.525	4.76	3.81	0.8	●
	150404E-PD3	12.7	4.76	5.16	0.4	●
	150408E-PD3	12.7	4.76	5.16	0.8	●
	DNMG 150404E-PC4	12.7	4.76	5.16	0.4	●
	150408E-PC4	12.7	4.76	5.16	0.8	●
	150604E-PC4	12.7	6.35	5.16	0.4	●
	150608E-PC4	12.7	6.35	5.16	0.8	●
	SNMG 120404E-PB1	12.7	4.76	5.16	0.4	●
	120408E-PB1	12.7	4.76	5.16	0.8	●
	SNMG 120404E-PC3	12.7	4.76	5.16	0.4	●
	120408E-PC3	12.7	4.76	5.16	0.8	●
	120412E-PC3	12.7	4.76	5.16	1.2	●
	SNMG 120404E-PD3	12.7	4.76	5.16	0.4	●
	120408E-PD3	12.7	4.76	5.16	0.8	●
	120412E-PD3	12.7	4.76	5.16	1.2	●
	SNMG 120404-M3T	12.7	4.76	5.16	0.4	●
	120408-M3T	12.7	4.76	5.16	0.8	●
	SNMG 120404E-PC4	12.7	4.76	5.16	0.4	●
	120408E-PC4	12.7	4.76	5.16	0.8	●
	120412E-PC4	12.7	4.76	5.16	1.2	●
	TNMG 160404E-PB1	9.525	4.76	3.81	0.4	●
	160408E-PB1	9.525	4.76	3.81	0.8	●
	160412E-PB1	9.525	4.76	3.81	1.2	●
	TNMG 160404R-M1T	9.525	4.76	3.81	0.4	●
	160404L-M1T	9.525	4.76	3.81	0.4	●
	TNMG 160404E-PB3	9.525	4.76	3.81	0.4	●
	160408E-PB3	9.525	4.76	3.81	0.8	●
	160412E-PB3	9.525	4.76	3.81	1.2	●
	TNMG 160404R-M2T	9.525	4.76	3.81	0.4	●
	160404L-M2T	9.525	4.76	3.81	0.4	●

◆ Product list

Insert	Product code	Dimension(mm)				Grade
		d	s	d1	r	AT202
	TNMG 160404E-PC3	9.525	4.76	3.81	0.4	●
	160408E-PC3	9.525	4.76	3.81	0.8	●
	160412E-PC3	9.525	4.76	3.81	1.2	●
	TNMG 160404E-PD3	9.525	4.76	3.81	0.4	●
	160408E-PD3	9.525	4.76	3.81	0.8	●
	160412E-PD3	9.525	4.76	3.81	1.2	●
	TNMG 160404R-PL5	9.525	4.76	3.81	0.4	●
	160408R-PL5	9.525	4.76	3.81	0.4	●
	160404L-PL5	9.525	4.76	3.81	0.8	●
	160408L-PL5	9.525	4.76	3.81	0.8	●
	TNMG 160404E-PC4	9.525	4.76	3.81	0.4	●
	160408E-PC4	9.525	4.76	3.81	0.8	●
	160412E-PC4	9.525	4.76	3.81	1.2	●
	VNMG 160404E-PB1	9.525	4.76	3.81	0.4	●
	160408E-PB1	9.525	4.76	3.81	0.8	●
	VNMG 160404E-PB3	9.525	4.76	3.81	0.4	●
	160408E-PB3	9.525	4.76	3.81	0.8	●
	160412E-PB3	9.525	4.76	3.81	1.2	●
	VNMG 160404E-PC3	9.525	4.76	3.81	0.4	●
	160408E-PC3	9.525	4.76	3.81	0.8	●
	160412E-PC3	9.525	4.76	3.81	1.2	●
	VNMG 160404E-PD3	9.525	4.76	3.81	0.4	●
	160408E-PD3	9.525	4.76	3.81	0.8	●
	160412E-PD3	9.525	4.76	3.81	1.2	●

Insert	Product code	Dimension(mm)				Grade
		d	s	d1	r	AT202
	VNMG 160404-M3T	9.525	4.76	3.81	0.4	●
	160408-M3T	9.525	4.76	3.81	0.8	●
	VNMG 160404E-PC4	9.525	4.76	3.81	0.4	●
	160408E-PC4	9.525	4.76	3.81	0.8	●
	160412E-PC4	9.525	4.76	3.81	1.2	●
	VNMG 160404E-BS	9.525	4.76	3.81	0.4	○
	160408E-BS	9.525	4.76	3.81	0.8	○
	WNMG 080404-F1T	9.525	4.76	5.16	0.4	●
	080408-F1T	9.525	4.76	5.16	0.8	●
	WNMG 080404E-PB1	12.7	4.76	5.16	0.4	●
	080408E-PB1	12.7	4.76	5.16	0.8	●
	080412E-PB1	12.7	4.76	5.16	1.2	●
	WNMG 080404E-PB3	12.7	4.76	5.16	0.4	●
	080408E-PB3	12.7	4.76	5.16	0.8	●
	080412E-PB3	12.7	4.76	5.16	1.2	●
	WNMG 080404E-PC3	12.7	4.76	5.16	0.4	●
	080408E-PC3	12.7	4.76	5.16	0.8	●
	080412E-PC3	12.7	4.76	5.16	1.2	●
	WNMG 080404E-PD3	12.7	4.76	5.16	0.4	●
	080408E-PD3	12.7	4.76	5.16	0.8	●
	080412E-PD3	12.7	4.76	5.16	1.2	●
	WNMG 080404-M3T	9.525	4.76	5.16	0.4	●
	080408-M3T	9.525	4.76	5.16	0.8	●
	WNMG 080404E-PC4	12.7	4.76	5.16	0.4	●
	080408E-PC4	12.7	4.76	5.16	0.8	●
	080412E-PC4	12.7	4.76	5.16	1.2	●



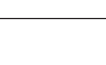

● Product list

Insert	Product code	Dimension(mm)				Grade
		d	s	d1	r	AT202
	CCMT 060202-F1T	6.35	2.38	2.8	0.2	●
	060204-F1T	6.35	2.38	2.8	0.4	●
	CCMT 060202E-PB1	6.35	2.38	2.8	0.2	●
	060204E-PB1	6.35	2.38	2.8	0.4	●
	060208E-PB1	6.35	2.38	2.8	0.8	●
	09T302E-PB1	9.525	3.97	4.4	0.2	●
	09T304E-PB1	9.525	3.97	4.4	0.4	●
	09T308E-PB1	9.525	3.97	4.4	0.8	●
		CCMT 060204E-PC2	6.35	2.38	2.8	0.4
060208E-PC2		6.35	2.38	2.8	0.8	●
09T304E-PC2		9.525	3.97	4.4	0.4	●
09T308E-PC2		9.525	3.97	4.4	0.8	●
120404E-PC2		12.7	4.76	5.5	0.4	●
120408E-PC2		12.7	4.76	5.5	0.8	●
120412E-PC2		12.7	4.76	5.5	1.2	●
	CCMT 09T304-M2T	9.525	3.97	4.4	0.4	●
	09T308-M2T	9.525	3.97	4.4	0.8	●
	CCMT 060204E-KC2	6.35	2.38	2.8	0.4	●
	060208E-KC2	6.35	2.38	2.8	0.8	●
	09T304E-KC2	9.525	3.97	4.4	0.4	●
	09T308E-KC2	9.525	3.97	4.4	0.8	●
	120404E-KC2	12.7	4.76	5.5	0.4	●
	120408E-KC2	12.7	4.76	5.5	0.8	●
	120412E-KC2	12.7	4.76	5.5	1.2	●
	DCMT 070202-F1T	6.35	2.38	2.8	0.2	●
	070204-F1T	6.35	2.38	2.8	0.4	●
	DCMT 11T302-F1T	9.525	3.97	4.4	0.2	○
	11T304-F1T	9.525	3.97	4.4	0.4	●
	11T308-F1T	9.525	3.97	4.4	0.8	●

Insert	Product code	Dimension(mm)				Grade
		d	s	d1	r	AT202
	DCMT 070202E-PB1	6.35	2.38	2.8	0.2	●
	070204E-PB1	6.35	2.38	2.8	0.4	●
	11T302E-PB1	9.525	3.97	4.4	0.2	●
	11T304E-PB1	9.525	3.97	4.4	0.4	●
	11T308E-PB1	9.525	3.97	4.4	0.8	●
	DCMT 070204E-PC2	6.35	2.38	2.8	0.4	●
	070208E-PC2	6.35	2.38	2.8	0.8	●
	11T304E-PC2	9.525	3.97	4.4	0.4	●
	11T308E-PC2	9.525	3.97	4.4	0.8	●
	11T312E-PC2	9.525	3.97	4.4	1.2	●
	DCMT 11T304-M2T	9.525	3.97	4.4	0.4	●
	11T308-M2T	9.525	3.97	4.4	0.8	●
	DCMT 070204E-KC2	6.35	2.38	2.8	0.4	●
	070208E-KC2	6.35	2.38	2.8	0.8	●
	11T304E-KC2	9.525	3.97	4.4	0.4	●
	11T308E-KC2	9.525	3.97	4.4	0.8	●
	SCMT 09T304E-PB1	9.525	3.97	4.4	0.4	●
	09T308E-PB1	9.525	3.97	4.4	0.8	●
	SCMT 09T304E-PC2	9.525	3.97	4.4	0.4	●
	09T308E-PC2	9.525	3.97	4.4	0.8	●
	120404E-PC2	12.7	4.76	5.5	0.4	●
	120408E-PC2	12.7	4.76	5.5	0.8	●
	SCMT 09T304-M2T	9.525	3.97	4.4	0.4	●
	09T308-M2T	9.525	3.97	4.4	0.8	●
	SCMT 09T304E-KC2	9.525	3.97	4.4	0.4	●
	09T308E-KC2	9.525	3.97	4.4	0.8	●
	120404E-KC2	12.7	4.76	5.5	0.4	●
	120408E-KC2	12.7	4.76	5.5	0.8	●

● Product list

Insert	Product code	Dimension(mm)				Grade
		d	s	d1	r	AT202
	TCMT 090204E-PB1	5.56	2.38	2.5	0.4	●
	110202E-PB1	6.35	2.38	2.8	0.2	●
	110204E-PB1	6.35	2.38	2.8	0.4	●
	110208E-PB1	6.35	2.38	2.8	0.8	●
	16T304E-PB1	9.525	3.97	4.4	0.4	●
	16T308E-PB1	9.525	3.97	4.4	0.8	●
	TCMT 090204E-PC2	5.56	2.38	2.5	0.4	●
	090208E-PC2	5.56	2.38	2.5	0.8	●
	110204E-PC2	6.35	2.38	2.8	0.4	●
	110208E-PC2	6.35	2.38	2.8	0.8	●
	16T304E-PC2	9.525	3.97	4.4	0.4	●
	16T308E-PC2	9.525	3.97	4.4	0.8	●
	TCMT 110204-M2T	6.35	2.38	2.8	0.4	●
	110208-M2T	6.35	2.38	2.8	0.8	●
	TCMT 16T304-M2T	6.35	2.38	4.4	0.4	●
	16T308-M2T	6.35	2.38	4.4	0.8	●

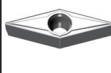
Insert	Product code	Dimension(mm)				Grade
		d	s	d1	r	AT202
	TCMT 090204E-KC2	5.56	2.38	2.5	0.4	●
	090208E-KC2	5.56	2.38	2.5	0.8	●
	110204E-KC2	6.35	2.38	2.8	0.4	●
	110208E-KC2	6.35	2.38	2.8	0.8	●
	16T304E-KC2	9.525	3.97	4.4	0.4	●
	16T308E-KC2	9.525	3.97	4.4	0.8	●
	TPMT 090204E-PC2	5.56	2.38	2.5	0.4	●
	090208E-PC2	5.56	2.38	2.5	0.8	●
	110304E-PC2	6.35	3.97	3.4	0.4	●
	110308E-PC2	6.35	3.97	3.4	0.8	●
	VBMT 110302E-PB1	6.35	3.18	2.8	0.2	●
	110304E-PB1	6.35	3.18	2.8	0.4	●
	110308E-PB1	6.35	3.18	2.8	0.8	●
	160404E-PB1	9.525	4.76	4.4	0.4	●
	160408E-PB1	9.525	4.76	4.4	0.8	●
	VBMT 110304E-PC2	6.35	3.18	2.8	0.4	●
	110308E-PC2	6.35	3.18	2.8	0.8	●
	160404E-PC2	9.525	4.76	4.4	0.4	●
	160408E-PC2	9.525	4.76	4.4	0.8	●
	VBMT 160404E-KC2	9.525	4.76	4.4	0.4	●
	160408E-KC2	9.525	4.76	4.4	0.8	●
	160412E-KC2	9.525	4.76	4.4	1.2	●