



ACHTECK
澳克泰工具

// 2025.01

Turning Toolholder Series



NO.099

www.achtecktool.com

External Toolholder Introduction

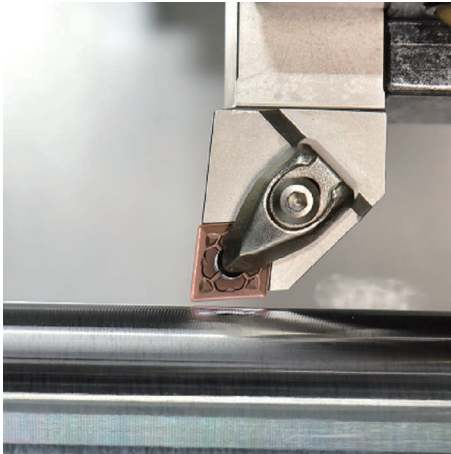

- Multiple insert clamping types and a wide range of tool shanks cover various working conditions
- Excellent clamping performance ensures the tool stability, keeps the stable turning and reduces the shank deformation
- The tool surface is treated with nickel-plating, enhancing both good looking and wear resistance

External Turning Shank

Clamping Type	Appearance	Structure	Features
Top wedge clamping (M)			Heavy turning, the clamping plate and eccentric pin are clamped simultaneously for a strong locking mechanism, ensuring stable turning
Rigid clamping (D)			Convenient operation, one step provides strong clamping to inserts from two directions, ensuring stable turning
Lever clamping (P)			Simple structure, convenient operation, wide application

Shank Exploded View

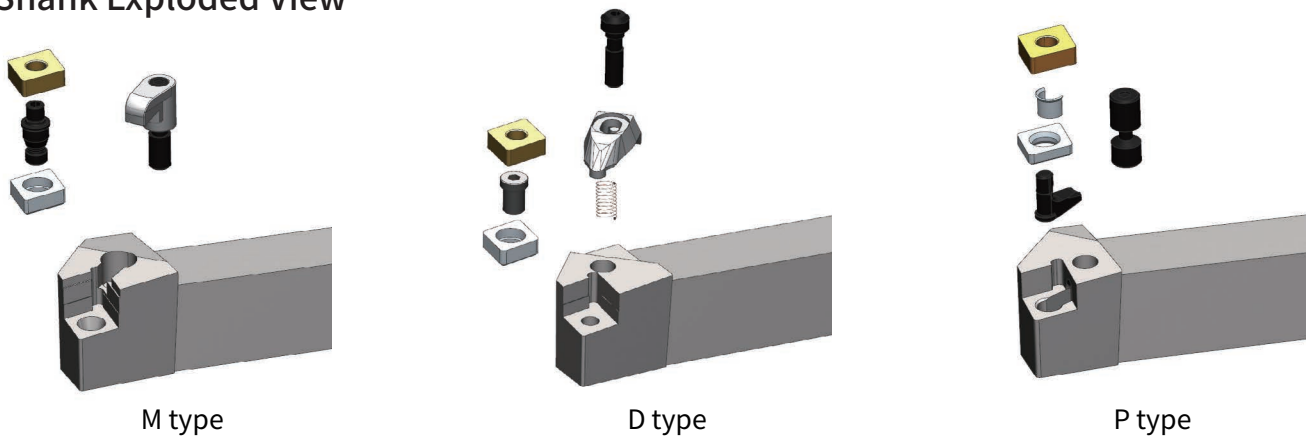

Internal Boring Shank

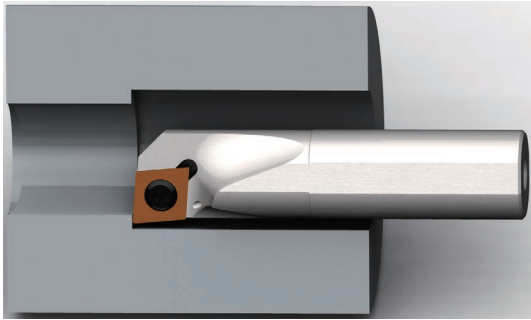

- Double-side chip pocket is designed for smoother chip removal
- The shank with thickest-structure can effectively prevent high-frequency vibration
- Minimum machining diameter $\phi 5\text{mm}$

SCLC Type

SDQC Type

STLC Type

SVUC Type

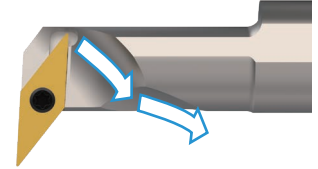
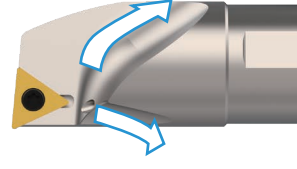
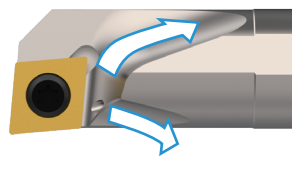
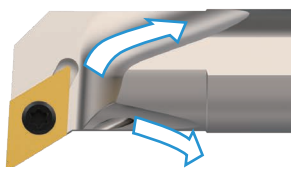

Chip evacuation performance R Rigidity Test

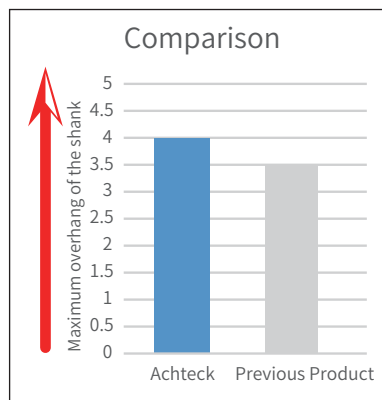
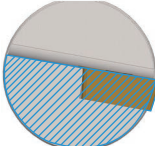
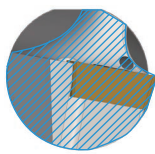
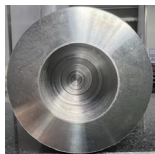

Achteck

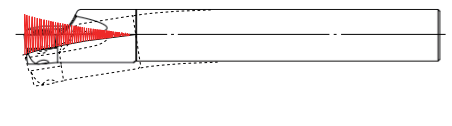

Previous Product

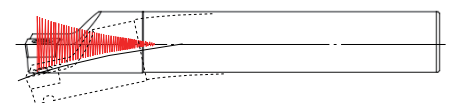

Cutting parameter:
 $V_c=260\text{m/min}$ $f=0.2\text{mm/rev}$ $a_p=0.6\text{mm}$ wet
 Workpiece material: 4140
 Tool shank: A20R-SDUCR11-20

Cutting parameter:
 $V_c=150\text{m/min}$ $f=0.1\text{mm/rev}$ $a_p=0.5\text{mm}$ wet
 Workpiece material: 45#
 Tool shank: A20R-SDUCR11-20

Negative Internal Tool Shank Introduction



Lever clamping





Top clamping

◆ Boring Tool Shanks

Insert shape	Shank	approaching angle	Material	Economy	Cutting force	Internal cooling	Deep hole
C type	A-SCLC	95°	Steel	low	low	With	/
	E-SCLC	95°	Carbide	high	high	With	Recommendation
	A-SCLP	95°	Steel	low	low	With	/
	E-SCLP	95°	Carbide	high	high	With	Recommendation
D type	A-SDUC	93°	Steel	low	low	With	/
	E-SDUC	93°	Carbide	high	high	With	Recommendation
	A-SDQC	107.5°	Steel	low	low	With	/
	E-SDQC	107.5°	Carbide	high	high	With	Recommendation
T type	A-STLC	95°	Steel	low	low	With	/
	A-STLP	95°	Steel	low	low	With	/
	E-STLP	95°	Carbide	high	high	With	Recommendation
V type	A-SVJC	52°	Steel	low	low	With	/
	A-SVPB	117.5°	Steel	low	low	With	/
	E-SVPB	117.5°	Carbide	high	high	With	Recommendation
	A-SVUB	93°	Steel	low	low	With	/
	E-SVUB	93°	Carbide	high	high	With	Recommendation
W type	A-SWUB	93°	Steel	low	low	With	/
	E-SWUB	93°	Carbide	high	high	With	Recommendation

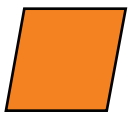
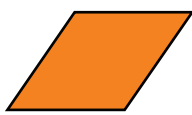
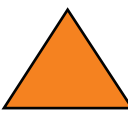
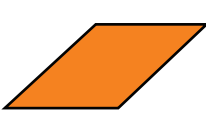
Illustration of insert shapes

C type	D type	T type	V type	W type
				

External Turning Toolholder Denomination System

D	C	L	N	R	20	20	K	12	Other Remarks
1	2	3	4	5	Height of shank	Width of shank	8	9	-

1-Clamping Type	
A: Back clamping	C: Top clamping
D: Double clamping	M: Multiple clamping
P: Lever clamping	S: Screw clamping
W: Wedge clamping	

2-Insert Shape	
C: 80° Rhombic	D: 55° Rhombic
R: Round	S: 90° Square
T: 60° Triangle	V: 35° Rhombic
W: 80° Trigon	

3-Approaching Angle									
A	90°	B	75°	L	95°	N	63°		
C	90°	D	45°	P	117.5°	R	75°		
E	60°	F	90°	S	45°	T	60°		
G	90°	H	107.5°	U	93°	V	72.5°		
J	93°	K	75°	W	60°	Y	85°		

4-Clearance Angle	
B: 5° positive angle	C: 7° positive angle
D: 15° positive angle	E: 20° positive angle
N: 0° negative angle	P: 11° positive angle

5-Hand of Tool
R: Right hand
L: Left hand
N: Left Neutral

8-Toolholder Length							
A: 32	B: 40	C: 50	D: 60	E: 70	F: 80	G: 90	H: 100
J: 110	K: 125	L: 140	M: 150	N: 160	P: 170	Q: 180	R: 200
R: 200	S: 250	T: 300	U: 350	V: 400	W: 450		

9-Length of Cutting Edge		

MCLN (External/Face Turning)

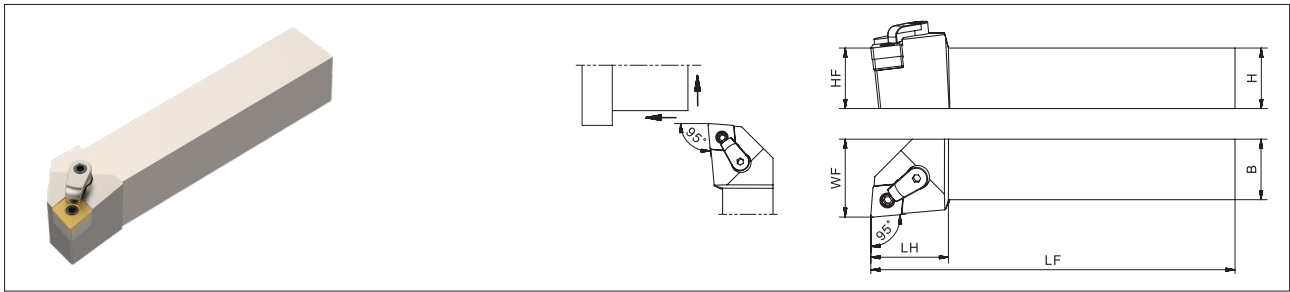

Product code	Stock		Dimension						Insert corner radius (RE)	Spare parts					Insert
	R	L	H	HF	B	LF	LH	WF		Wrench	Clamp screw	Clamp	Lock pin	Shim	
MCLN ^{R/L} 2020K-12	●	●	20	20	20	125	33	35	0.8						CN*A 1204... CN*G 1204... CN*M 1204...
2525M-12	●	●	25	25	25	150	32	32		LT-H3	CD060255X	CLM180130	CS060170	S-MCN12048	

● : Standard stock ○ : Made-to-Order

DCLN (External/Face Turning)

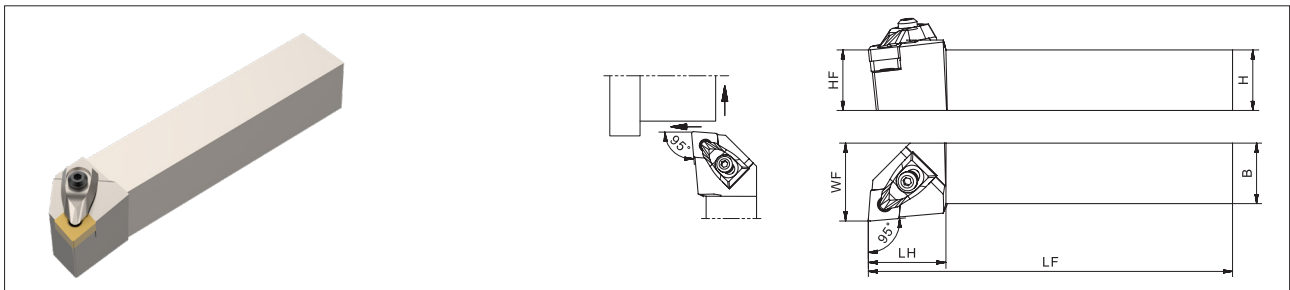

Product code	Stock		Dimension						Insert corner radius (RE)	Spare parts						Insert
	R	L	H	HF	B	LF	LH	WF		Wrench	Clamp screw	Clamp	Spring	Shim screw	Shim	
DCLN ^{R/L} 2020K-12	●	●	20	20	20	125	32	25	0.8							CN*A 1204... CN*G 1204... CN*M 1204...
2525M-12	●	●	25	25	25	150		32		LT-H3	CH050215	CLD255090	YB0.20-2.50-12-5.5	SH060100X	S-DCN12048	

● : Standard stock ○ : Made-to-Order

PCLN (External/Face Turning)

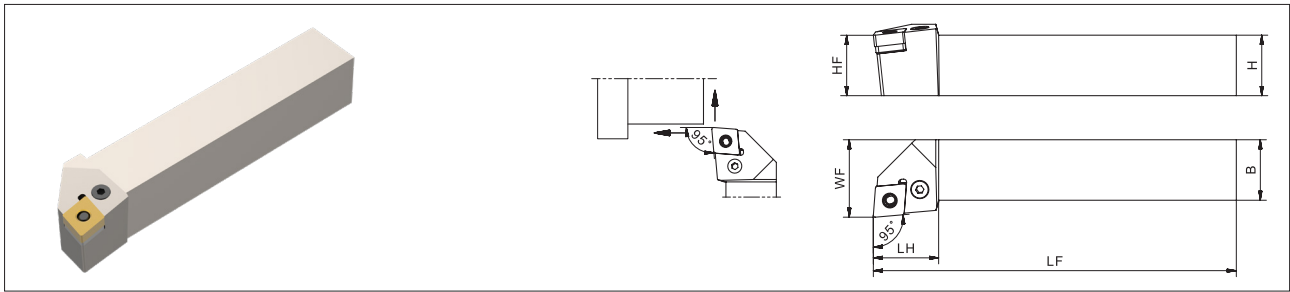

Product code	Stock		Dimension						Insert corner radius (RE)	Spare parts					Insert																
			H	HF	B	LF	LH	WF		Wrench	Lever screw	Lever	Shim	Shim pin																	
	R	L																													
PCLN ^{R/L} 1616H-0903	○	○	16	16	16	100		20	0.8	LT-H2.5	LH060170	LV3	S-PCN09032	SP3	CN*G 0903...																
	○	○	20	20	20	125	22	25																							
	○	○	25	25	25	150		32																							
PCLN ^{R/L} 1616H-12	○	○	16	16	16	100		20		0.8	LT-H3	LH080200	LV4C	S-PCN12032		SP4N	CN*A 1204... CN*G 1204... CN*M 1204...														
	○	●	20	20	20	125	27	25																							
	●	●	25	25	25	150		32																							
	○	○	32	32	32	170		40																							
PCLN ^{R/L} 2525M-16	○	○	25	25	25	150		32										1.2	LT-H4	LH080235	LV5	S-PCN16048	SP5	CN*A 1606... CN*G 1606... CN*M 1606...							
	○	○	32	32	32	170	32	40																							
	○	○	40	40	40	250		50																							
PCLN ^{R/L} 3232P-19	○	○	32	32	32	170		40	2.4		LT-H5	LH120360	LV8	S-PCN19048	SP6	CN*A 1906... CN*G 1906... CN*M 1906...															
	○	○	40	40	40	250	38	50																							
PCLN ^{R/L} 3232P-2507	○	○	32	32	32	170		45											2.4	LT-H5	LH120360	LV8	S-PCN25080		SP8N	CN*A 2507... CN*G 2507... CN*M 2507...					
	○	○	40	40	40	250	45	45																							
PCLN ^{R/L} 3232P-2509	○	○	32	32	32	170		45																			2.4	LT-H5	LH120360	LV8	S-PCN25064
	○	○	40	40	40	250	45	45																							

● : Standard stock ○ : Made-to-Order

MDJN (External/Profile Turning)

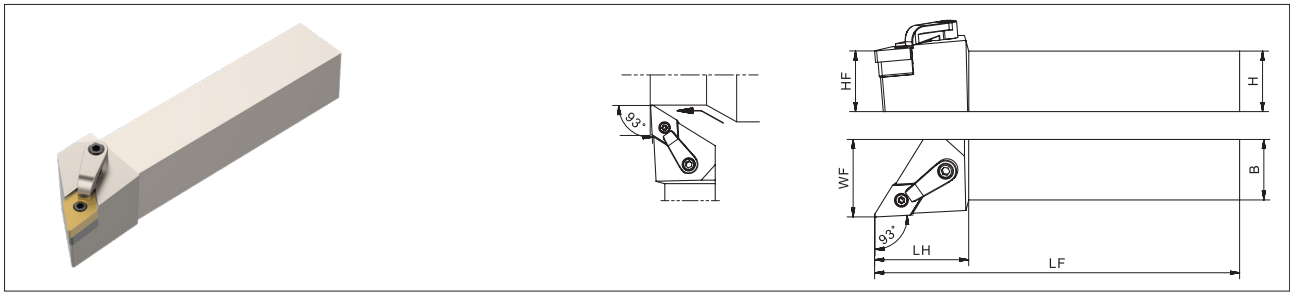

Product code	Stock		Dimension					Insert corner radius (RE)	Spare parts					Insert	
	R	L	H	HF	B	LF	LH		WF	Wrench	Clamp screw	Clamp	Lock pin		Shim
										LT-H3	CD060255X	CLM210140	CS060190		S-MDN15064
MDJN ^{R/L} 2020K-1504	○	○	20	20	20	125	39	25	0.8	LT-H3	CD060255X	CLM210140	CS060190	S-MDN15064	DN*A 1504...
2525M-1504	●	○	25	25	25	150									32
MDJN ^{R/L} 2020K-1506	○	○	20	20	20	125	39	25	0.8	LT-H3	CD060255X	CLM210140	CS060190	S-MDN15048	DN*A 1506...
2525M-1506	○	○	25	25	25	150									32

● : Standard stock ○ : Made-to-Order

DDJN (External/Profile Turning)

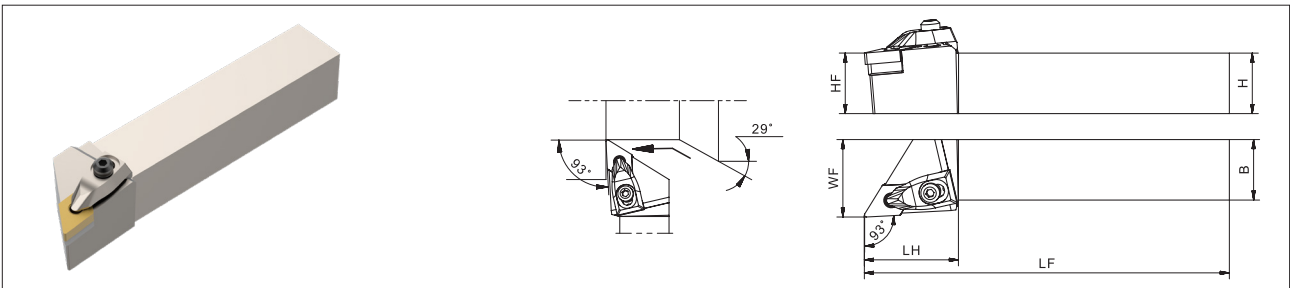







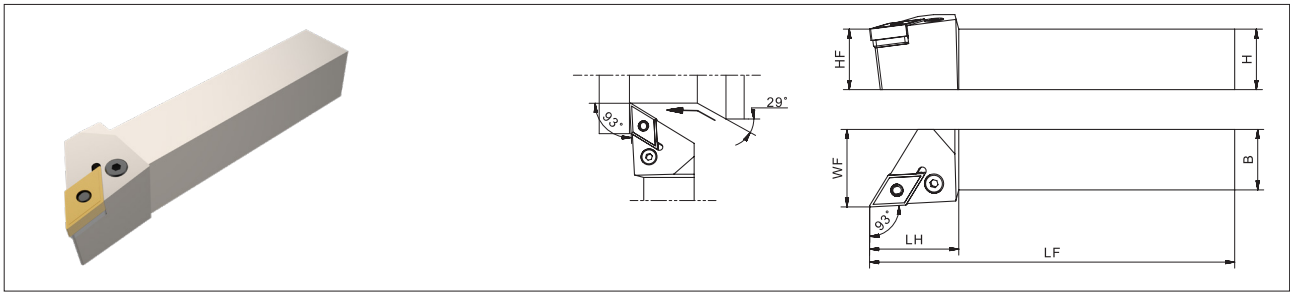













Product code	Stock		Dimension					Insert corner radius (RE)	Spare parts						Insert	
	R	L	H	HF	B	LF	LH		WF	Wrench	Clamp screw	Clamp	Spring	Shim screw		Shim
										LT-H3	CH050215	CLD283090	YB0.20-2.50-12-5.5	SH060100X		S-DDN15064
DDJN ^{R/L} 2020K-1504	○	○	20	20	20	125	39	25	0.8	LT-H3	CH050215	CLD283090	YB0.20-2.50-12-5.5	SH060100X	S-DDN15064	DN*A 1504...
2525M-1504	●	○	25	25	25	150										32
DDJN ^{R/L} 2020K-1506	○	○	20	20	20	125	39	25	0.8	LT-H3	CH050215	CLD283090	YB0.20-2.50-12-5.5	SH060100X	S-DDN15048	DN*A 1506...
2525M-1506	○	○	25	25	25	150										32

● : Standard stock ○ : Made-to-Order

PDJN (External/Profile Turning)



Product code	Stock		Dimension							Insert corner radius (RE)	Spare parts					Insert
	R	L	H	HF	B	LF	LH	WF	Wrench		Lever screw	Lever	Shim	Shim pin		
																
PDJN ^{R/L} 1616H-11	○	○	16	16	16	100	28	20	0.4						DN*G 1104...	
2020K-11	●	●	20	20	20	125	25									
2525M-11	●	●	25	25	25	150	36	32								
PDJN ^{R/L} 2020K-1504	●	○	20	20	20	125	36	25	0.8						DN*A 1504... DN*G 1504... DN*M 1504...	
2525M-1504	●	●	25	25	25	150		32								
3232P-1504	○	○	32	32	32	170		40								
PDJN ^{R/L} 2020K-1506	○	○	20	20	20	125	36	25	0.8						DN*A 1506... DN*G 1506... DN*M 1506...	
2525M-1506	○	○	25	25	25	150		32								
3232P-1506	○	○	32	32	32	170		40								

● : Standard stock ○ : Made-to-Order

DSBN (External Turning)

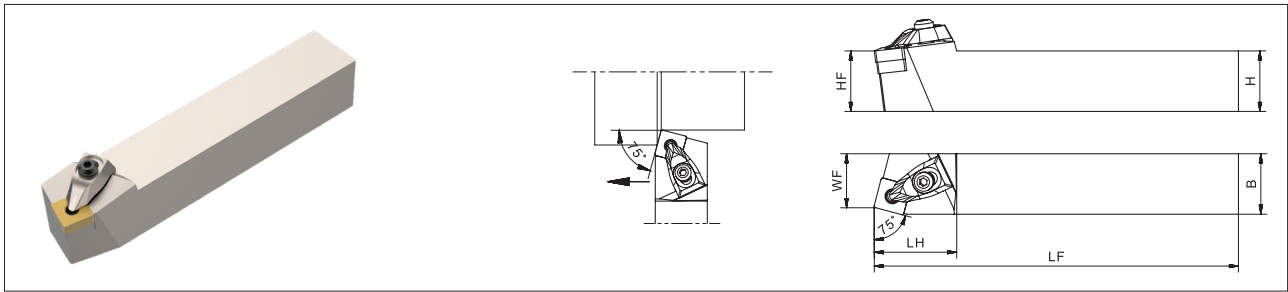

Product code	Stock		Dimension					Insert corner radius (RE)	Spare parts						Insert						
	R	L	H	HF	B	LF	LH		WF	Wrench	Clamp screw	Clamp	Spring	Shim screw		Shim					
DSBN ^{R/L} 2020K-12	○	○	20	20	20	125	17	0.8							SN*A 1204... SN*G 1204... SN*M 1204...						
	●	○	25	25	25	150	34									22	CH050215	CLD255090	YB0.20-2.50-12-5.5	SH060080X	S-DSN12048
	○	○	32	32	32	170	27									27	CLD283090	SH060100X	S-DSN15048	SN*A 1506... SN*G 1506... SN*M 1506...	
DSBN ^{R/L} 2525M-15	○	○	25	25	25	150	41	22	LT-H3							SN*A 1506... SN*G 1506... SN*M 1506...					
	○	○	32	32	32	170	27	27									CH080235	CLD380150	YB0.40-2.50-15-8.5	SH060130X	S-DSN25080
DSBN ^{R/L} 4040S-2507	○	○	40	40	40	250	56	35	1.6							SN*A 2509... SN*G 2509... SN*M 2509...					
DSBN ^{R/L} 4040S-2509	○	○														SN*A 2509... SN*G 2509... SN*M 2509...					

● : Standard stock ○ : Made-to-Order

PSBN (External Turning)

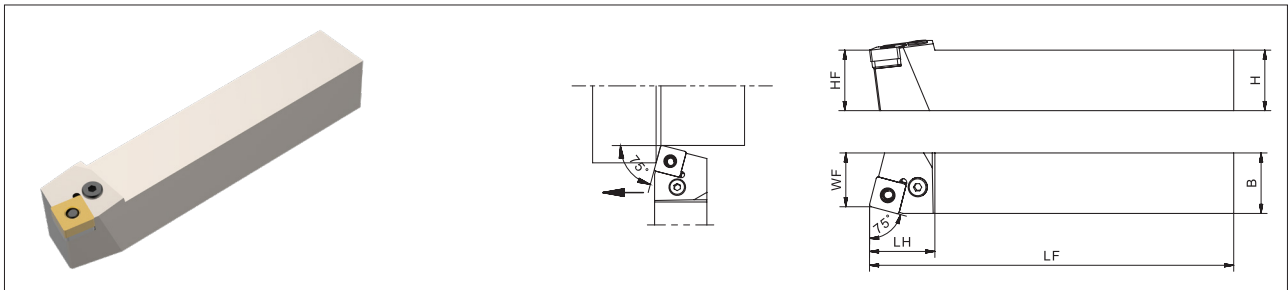

Product code	Stock		Dimension					Insert corner radius (RE)	Spare parts					Insert	
	R	L	H	HF	B	LF	LH		WF	Wrench	Lever screw	Lever	Shim		Shim pin
PSBN ^{R/L} 2020K-12	●	○	20	20	20	125	27	17	0.8	LT-H3					SN*A 1204... SN*G 1204... SN*M 1204...
	●	●	25	25	25	150	22	22							
PSBN ^{R/L} 2525M-12	●	●	25	25	25	150									SN*A 1204... SN*G 1204... SN*M 1204...

● : Standard stock ○ : Made-to-Order

DSBN (External Turning)

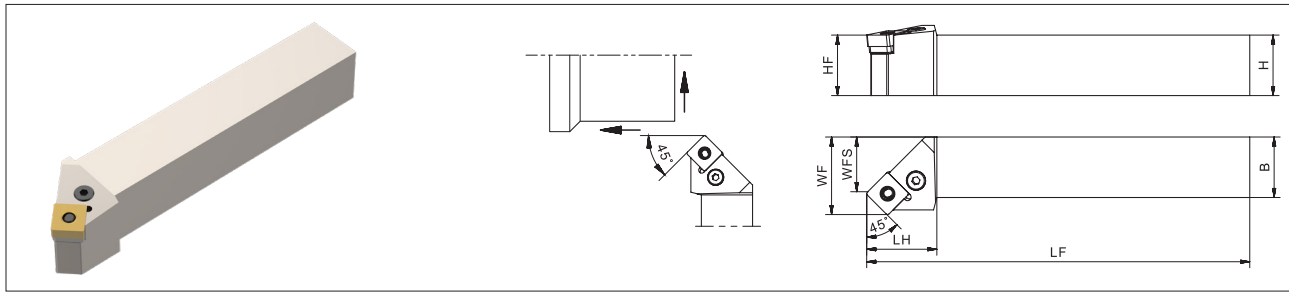

Product code	Stock		Dimension							Insert corner radius (RE)	Spare parts					Insert
	R	L	H	HF	B	LF	LH	WF	WFS		Wrench	Lever screw	Lever	Shim	Shim pin	
	PSSN ^{R/L} 2020K-12	○	○	20	20	20	125		25		16.4	0.8	LT-H3	LH080200	LV4C	
2525M-12	●	●	25	25	25	150	29	32	23.4							
3232P-12	○	○	32	32	32	170		40	31.4							
PSSN ^{R/L} 2525M-15	○	○	25	25	25	150		32	21.27	1.2	LT-H4	LH100270	LV6	S-PSN19048	SP6	SN*G 1906... SN*M 1906...
3232P-15	○	○					32		29.1							
PSSN ^{R/L} 3232P-19	○	○	32	32	32	170		40	27							
4040S-19	○	○	40	40	40	250		50	37							

● : Standard stock ○ : Made-to-Order

PSDN (External/Chamfer Turning)

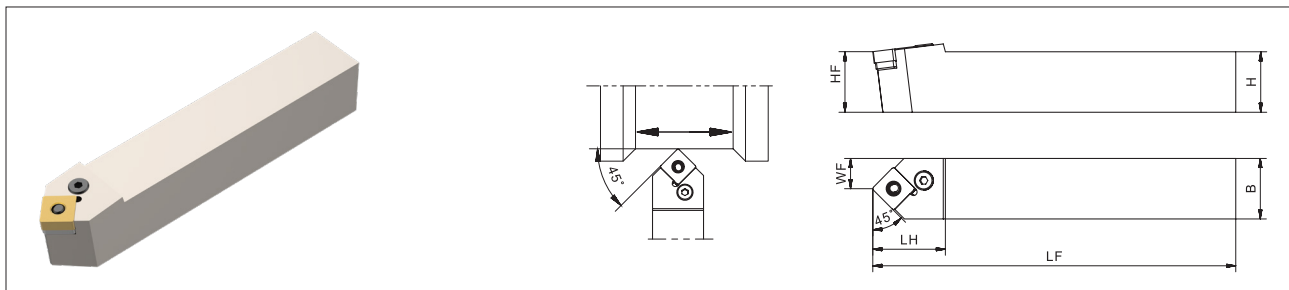

Product code	Stock		Dimension							Insert corner radius (RE)	Spare parts					Insert
	N		H	HF	B	LF	LH	WF	Wrench		Lever screw	Lever	Shim	Shim pin		
	PSDNN 2020K-12	○		20	20	20	125		10		0.8	LT-H3	LH080200	LV4C	S-PSN12032	
2525M-12	●		25	25	25	150	30	12.5								

● : Standard stock ○ : Made-to-Order

PTGN (External Turning)

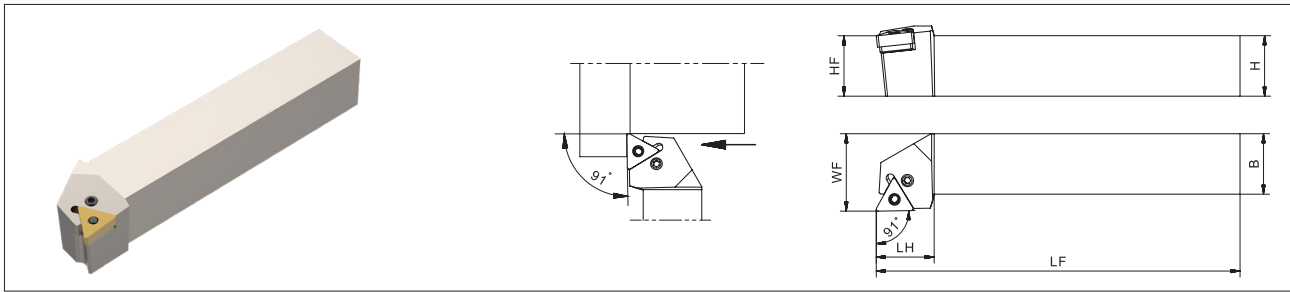

Product code	Stock		Dimension						Insert corner radius (RE)	Spare parts					Insert
	R	L	H	HF	B	LF	LH	WF		Wrench	Lever screw	Lever	Shim	Shim pin	
										LT-H2.5	LH060170	LV3	S-PTN16027	SP3	
PTGN ^{R/L} 1616H-16	○	○	16	16	16	100		20	0.8						TN*A 1604... TN*G 1604... TN*M 1604...
2020K-16	●	●	20	20	20	125	24	25							
2525M-16	●	●													
PTGN ^{R/L} 2525M-22	●	●	25	25	25	150		28	32						TN*A 2204... TN*G 2204... TN*M 2204...

● : Standard stock ○ : Made-to-Order

DTGN (External Turning)

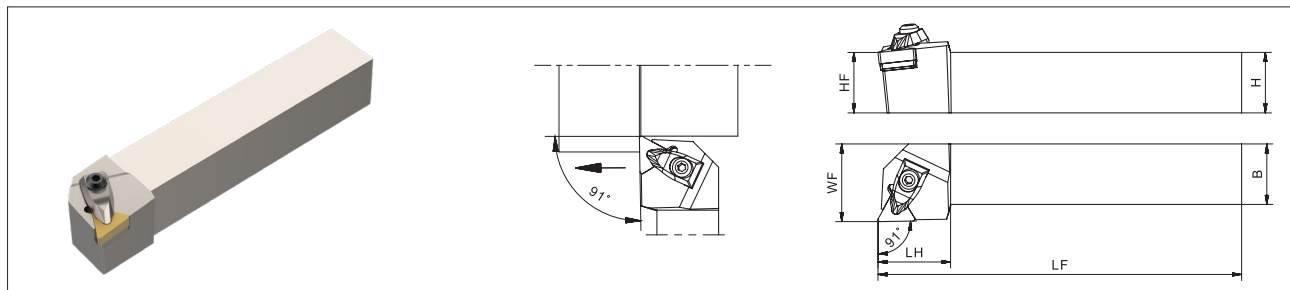

Product code	Stock		Dimension						Insert corner radius (RE)	Spare parts						Insert
	R	L	H	HF	B	LF	LH	WF		Wrench	Clamp screw	Clamp	Spring	Shim screw	Shim	
										LT-H3	CH050215	CLD225075	YB0.20-2.50-12-5.5	SH050140X	S-DTN16032	
DTGN ^{R/L} 2020K-16	○	○	20	20	20	125		25	0.8						TN*A 1604... TN*G 1604... TN*M 1604...	
2525M-16	○	○	25	25	25	150		32								

● : Standard stock ○ : Made-to-Order

MVJN (External/Profile Turning)

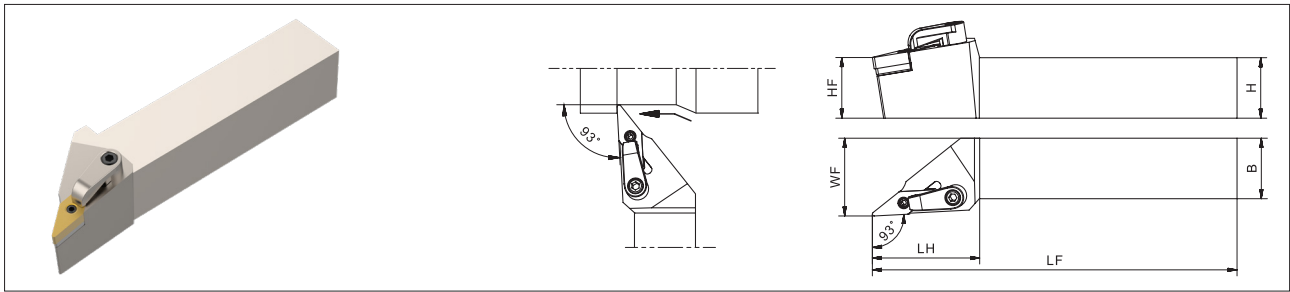

Product code	Stock		Dimension							Insert corner radius (RE)	Spare parts					Insert
			H	HF	B	LF	LH	WF	Wrench		Clamp screw	Clamp	Lock pin	Shim		
	R	L														
MVJN ^{R/L}	2020K-16	●	●	20	20	20	125	44	25	0.8	LT-H2/LT-H3	CD060255X	CLM240130	CS050140	S-MVN16032	VN*A 1604... VN*G 1604... VN*M 1604...
	2525M-16	●	●	25	25	25	150	44	32	0.8						

● : Standard stock ○ : Made-to-Order

DVJN (External/Profile Turning)

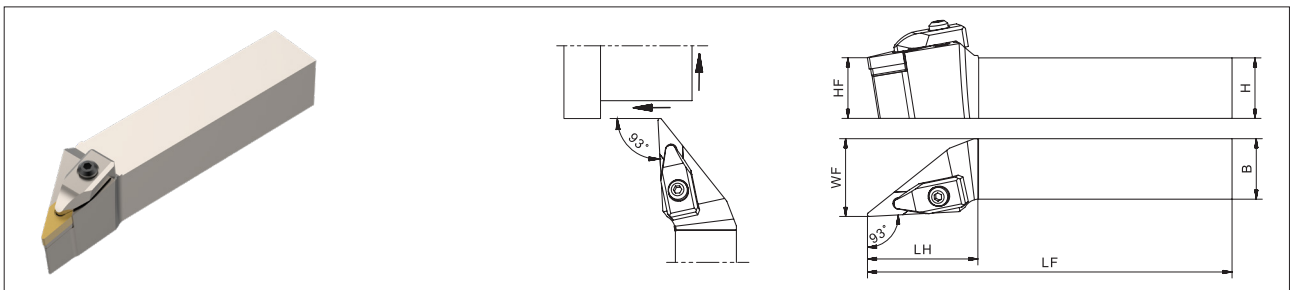

Product code	Stock		Dimension							Insert corner radius (RE)	Spare parts						Insert
			H	HF	B	LF	LH	WF	Wrench		Clamp screw	Clamp	Spring	Shim screw	Shim		
	R	L															
DVJN ^{R/L}	2020K-16	○	○	20	20	20	125	46	25	0.8	LT-H3	CH050215	CLD296090	YB0.20-2.50-12-5.5	SH050080X	S-DVN16033	VN*A 1604... VN*G 1604... VN*M 1604...
	2525M-16	○	○	25	25	25	150	32	0.8								

● : Standard stock ○ : Made-to-Order

PVLN (External/Profile Turning)

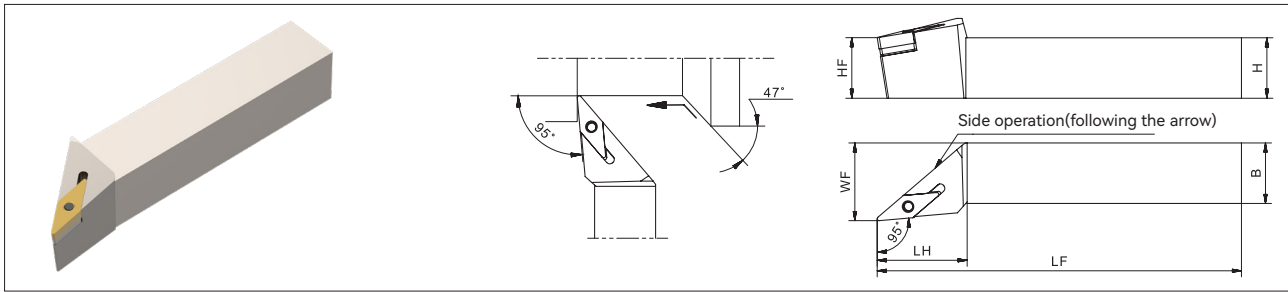

Product code	Stock		Dimension							Insert corner radius (RE)	Spare parts				Insert
	R	L	H	HF	B	LF	LH	WF	Wrench		Lever screw	Lever	Shim		
PVLN^{R/L}															
2020K-16	○	○	20	20	20	125		25	0.8	LT-H3	AH060125	LC3	S-PVN16032	VN*A 1604... VN*G 1604... VN*M 1604...	
2525M-16	●	●	25	25	25	150	37	32							

● : Standard stock ○ : Made-to-Order

PVPN (External/Face/Profile/undercut Turning)

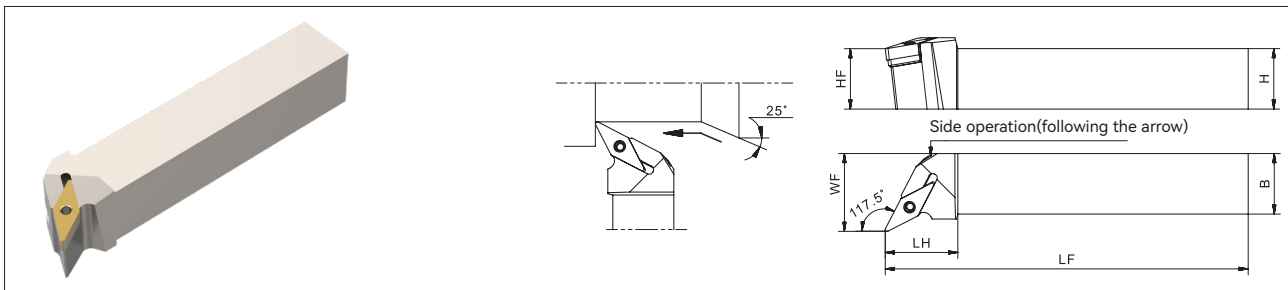

Product code	Stock		Dimension							Insert corner radius (RE)	Spare parts				Insert
	R	L	H	HF	B	LF	LH	WF	Wrench		Lever screw	Lever	Shim		
PVPN^{R/L}															
2020K-16	○	○	20	20	20	125		25	0.8	LT-H3	AH060125	LC3	S-PVN16032	VN*A 1604... VN*G 1604... VN*M 1604...	
2525M-16	●	○	25	25	25	150	30	32							

● : Standard stock ○ : Made-to-Order

MVVN (External/Profile Turning)

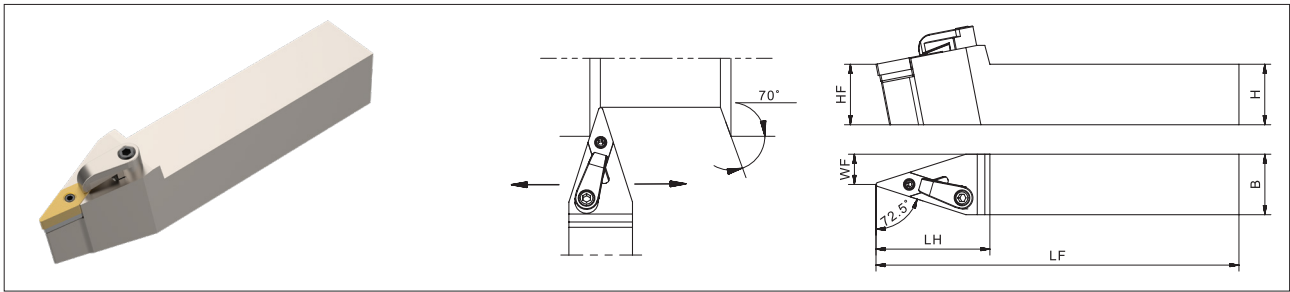

Product code	Stock	Dimension							Insert corner radius (RE)	Spare parts					Insert
		H	HF	B	LF	LH	WF	Wrench		Clamp screw	Clamp	Lock pin	Shim		
	N														
MVVNN 2020K-16	●	20	20	20	125	47	10	0.8	LT-H2/LT-H3	CD060255X	CLM240130	CS050140	S-MVN16032	VN*A 1604... VN*G 1604... VN*M 1604...	
	●	25	25	25	150	47	12.5								

● : Standard stock ○ : Made-to-Order

DVVN (External/Profile Turning)

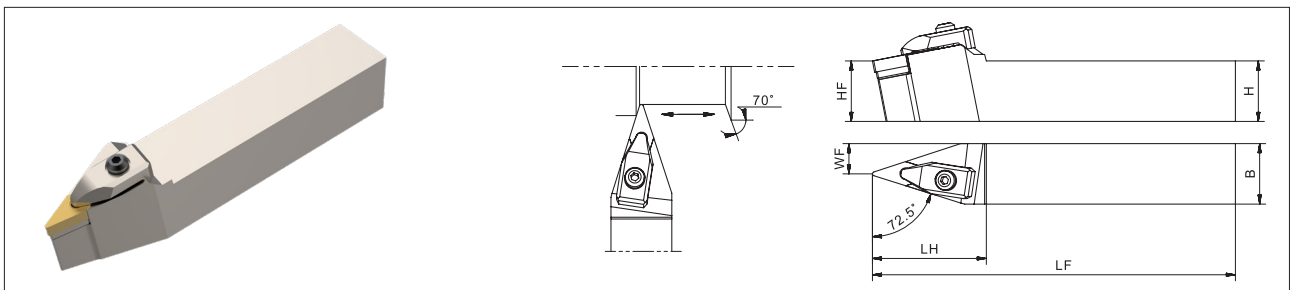

Product code	Stock	Dimension							Insert corner radius (RE)	Spare parts						Insert
		H	HF	B	LF	LH	WF	Wrench		Clamp screw	Clamp	Spring	Shim screw	Shim		
	N															
DVVNN 2020K-16	○	20	20	20	125	47	10	0.8	LT-H3	CH050215	CLD296090	YB0.20-2.50-12-5.5	SH050080X	S-DVN16033	VN*A 1604... VN*G 1604... VN*M 1604...	
	○	25	25	25	150											12.5

● : Standard stock ○ : Made-to-Order

PVVN (External/Profile Turning)

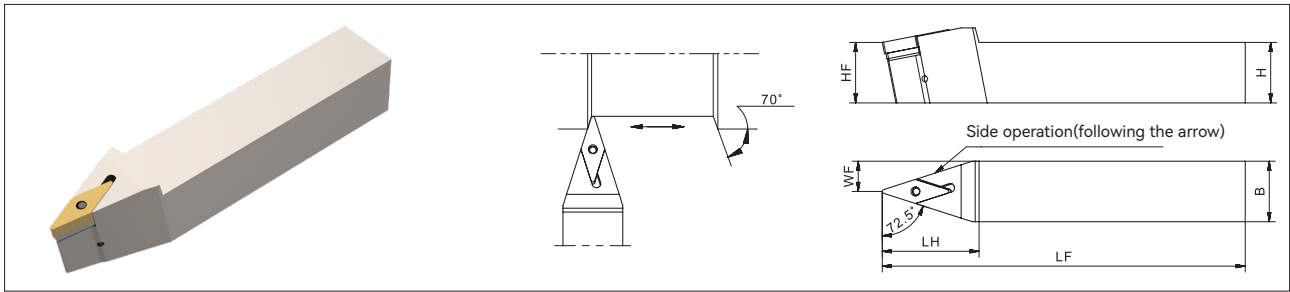

Product code	Stock		Dimension						Insert corner radius (RE)	Spare parts				Insert
	N	○	H	HF	B	LF	LH	WF		Wrench	Lever screw	Lever	Shim	
PVVNN	2020K-16	○	20	20	20	125	35	10	0.8	LT-H3	AH060125	LC3	S-PVN16032	VN*A 1604... VN*G 1604... VN*M 1604...
	2525M-16	●	25	25	25	150	40	12.5						

● : Standard stock ○ : Made-to-Order

MWLN (External/Profile Turning)

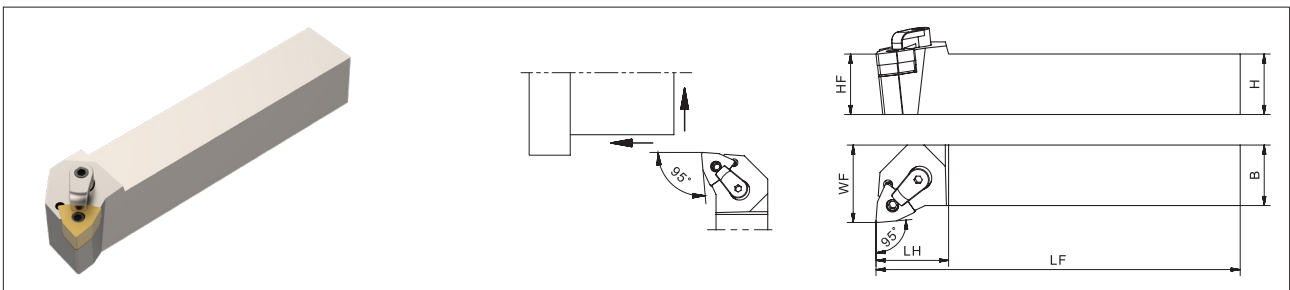

Product code	Stock		Dimension						Insert corner radius (RE)	Spare parts					Insert	
	R	L	H	HF	B	LF	LH	WF		Wrench	Clamp screw	Clamp	Lock pin	Shim		
MWLN^{R/L}	2020K-08	●	●	20	20	20	125	34	25	0.8	LT-H3	CD060255X	CLM180130	CS060170	S-MWN08048	WN*A 0804... WN*G 0804... WN*M 0804...
	2525M-08	●	●	25	25	25	150	30	32							

● : Standard stock ○ : Made-to-Order

DWLN (External/Face Turning)

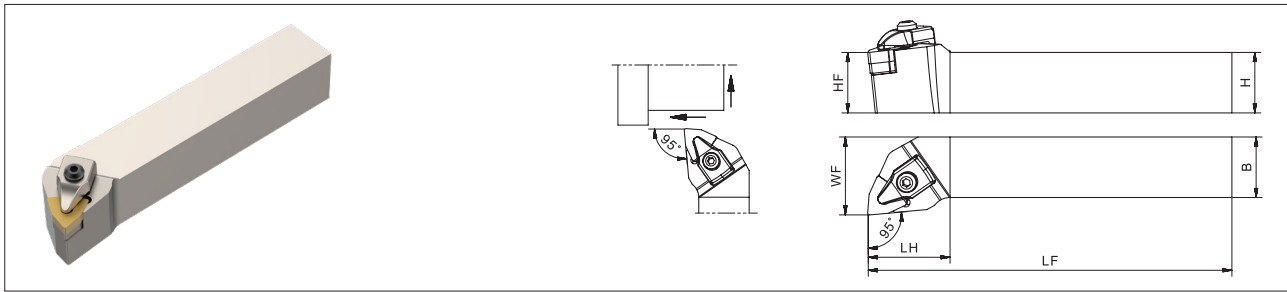

Product code	Stock		Dimension						Insert corner radius (RE)	Spare parts						Insert
	R	L	H	HF	B	LF	LH	WF		Wrench	Clamp screw	Clamp	Spring	Shim screw	Shim	
DWLN ^{R/L} 2020K-08	○	○	20	20	20	125	34	25	0.8							WN*A 0804... WN*G 0804... WN*M 0804...
2525M-08	○	○	25	25	25	150	32	LT-H3								

● : Standard stock ○ : Made-to-Order

PWLN (External/Face Turning)

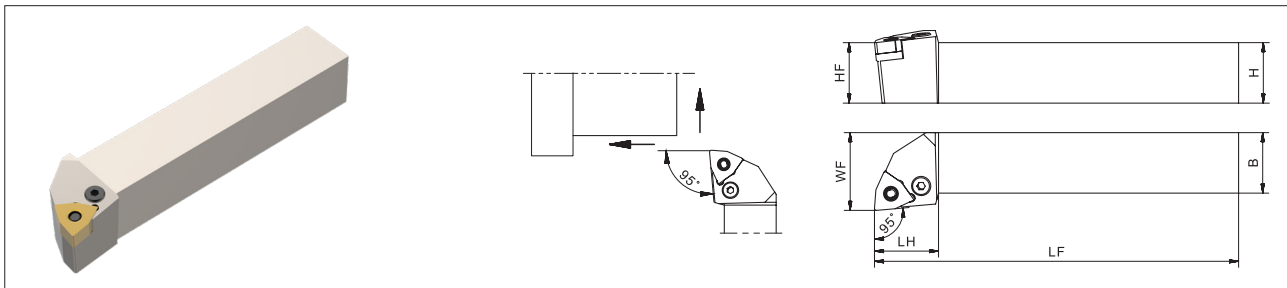

Product code	Stock		Dimension						Insert corner radius (RE)	Spare parts					Insert					
	R	L	H	HF	B	LF	LH	WF		Wrench	Lever screw	Lever	Shim	Shim pin						
PWLN ^{R/L} 1616H-06	○	○	16	16	16	100		20	0.8						WN*G 0604...					
2020K-06	●	○	20	20	20	125	22	25								LT-H2.5	LH060170	LV3	S-PWN06027	SP3
2525M-06	●	●	25	25	25	150		32												
PWLN ^{R/L} 2020K-08	●	●	20	20	20	125		25	0.8						WN*A 0804... WN*G 0804... WN*M 0804...					
2525M-08	●	●	25	25	25	150	26	32								LT-H3	LH080200	LV4C	S-PWN08032	SP4N

● : Standard stock ○ : Made-to-Order

Internal Boring bar Denomination System

A	20	R	-	S	C	L	C	R	09	-	22
1	2	3		4	5	6	7	8	9		Min. Boring Dia.

1-boring bar Material		2- Shank Diameter	3-boring bar Length		4-Clamping Type	
S: Steel shank	A: Steel shank (with internal coolant)	20mm	Q: 180	R: 200	C: Top clamping	W: Wedge clamping
C: Carbide shank	E: Carbide shank (with internal coolant)		S: 250	T: 300	S: Screw clamping	P: Lever clamping
			U: 350	V: 400	M: Multiple clamping	
			W: 450	Y: 500		

5-Insert shape		6-Approaching Angle											
C: 80° Rhombic	D: 55° Rhombic	F	90°	E	75°	L	95°	P	117.5°	Q	107.5°	S	45°
R: Round	S: 90° Square	U	93°	W	60°	Y	85°	X	110°	Z	93° (95°)		
T: 60° Triangle	V: 35° Rhombic												
W: Trigon													

7-Clearance Angle		8-Hand of Tool	9-Length of Cutting Edge		
B: 5° positive angle	C: 7° positive angle	R: Right hand			
D: 15° positive angle	E: 20° positive angle	L: left hand			
N: 0° Negative angle	P: 11° positive angle	N: Neutral			

S/A-SCLC Steel boring bar (Internal /Internal Face Boring)

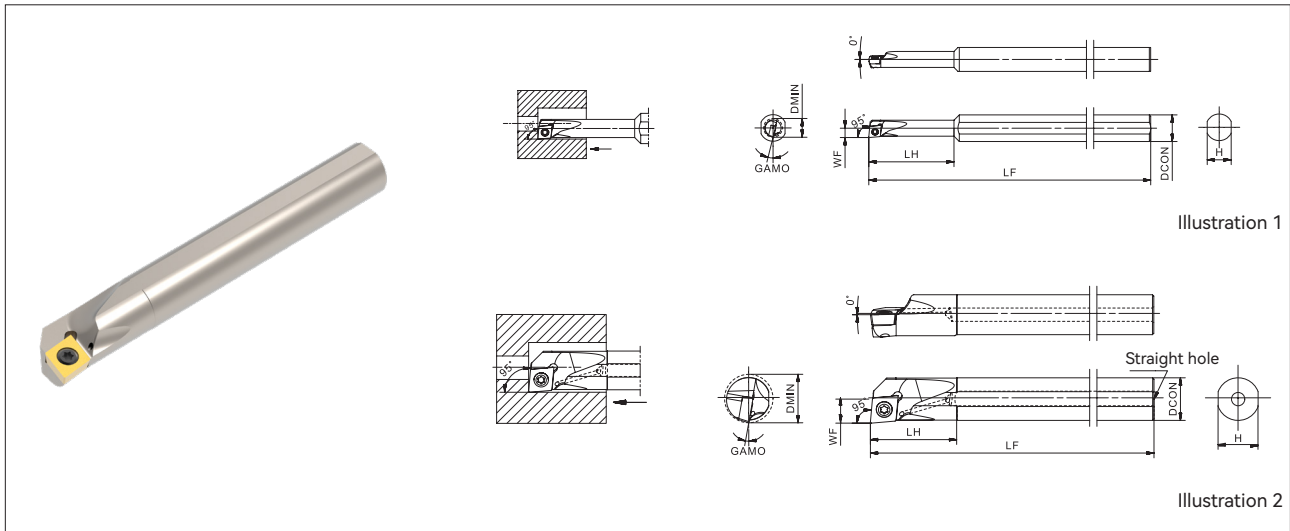

Product code	Stock		Minimum boring hole diameter (mm)	Dimension						Insert corner radius (RE)	Internal Coolant	Illustration	Spare parts		Insert
	R	L		DCON	H	LF	LH	WF	GAMO				Screw	Wrench	
			DMIN												
S10H-SCLCR/L03-05	○	○	5	10	9	100	24	2.5	15°	0.2	Without	1	SP016032	FT-TP05	CC*T 0301... CC*W 0301...
S10H-SCLCR/L03-06	○	○	6				28	3	13°						
S10H-SCLCR/L04-07	●	●	7				32	3.5	14°						
S10H-SCLCR/L04-08	○	○	8				37	4	11°						
A08H-SCLCR/L06-10	●	●	10	8	7	100	16	5	14°	0.4	With	2	SP025045	FT-TP08	CC*T 0602... CC*W 0602...
A10K-SCLCR/L06-12	●	●	12	10	9	125	22	6	12°						
A12M-SCLCR/L06-14	●	●	14	12	11	150	26	7	10°						
A16Q-SCLCR/L09-18	●	●	18	16	15	180	32.4	9	8°						
A20R-SCLCR/L09-22	●	●	22	20	19	200	38.5	11							
A25S-SCLCR/L09-27	○	○	27	25	24	250	46	13.5					6°		
													SP040065	FT-TP15	CC*T 09T3... CC*W 09T3...
													SP040093X		

● : Standard stock ○ : Made-to-Order

C/E-SCLC Carbide boring bar (Internal/Internal Face Boring)

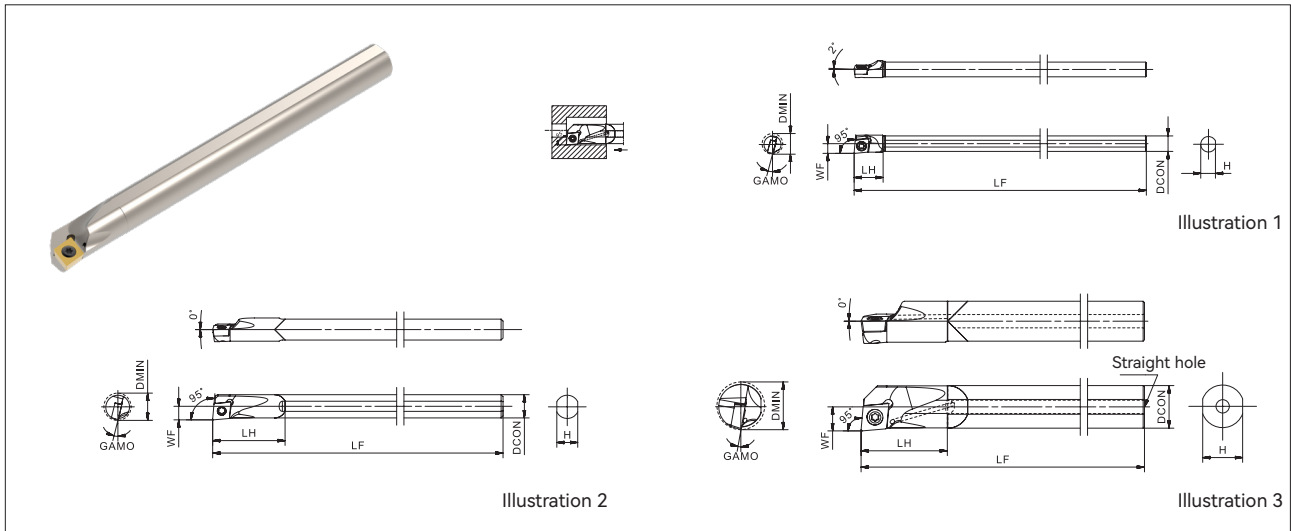

Product code	Stock		Minimum boring hole diameter (mm)	Dimension						Insert corner radius (RE)	Internal Coolant	Illustration	Spare parts		Insert	
	R	L		DCON	H	LF	LH	WF	GAMO				Screw	Wrench		
			DMIN													
C04F-SCLCR/L03-05	○	○	5	4	3.8	80	7	2.5	15°	0.2	Without	1	SP016032	FT-TP05	CC*T 0301... CC*W 0301...	
C05G-SCLCR/L03-06	○	○	6	5	4.4	90	9	3	13°			2	SP020035	FT-TP06	CC*T 0401... CC*W 0401...	
C06H-SCLCR/L04-07	●	●	7	6	5.4	100	14	3.5	14°		0.4	With	3	SP025045	FT-TP08	CC*T 0602... CC*W 0602...
C07J-SCLCR/L04-08	○	○	8	7	6.4	110	11	4	11°				SP040065	FT-TP15	CC*T 09T3... CC*W 09T3...	
E08K-SCLCR/L06-10	○	○	10	8	7	125	14	5	14°	SP040093X						
E10M-SCLCR/L06-12	○	○	12	10	9	150	18	6	12°							
E12M-SCLCR/L06-14	●	●	14	12	11	150	27	7	10°							
E16Q-SCLCR/L09-18	●	●	18	16	15	180	32.4	9	10°							
E20R-SCLCR/L09-22	○	○	22	20	19	200	32	11	8°							
E25S-SCLCR/L09-27	○	○	27	25	24	250	38	13.5	6°							

● : Standard stock ○ : Made-to-Order

A-SCLP Steel boring bar (Internal/Internal Face Boring)

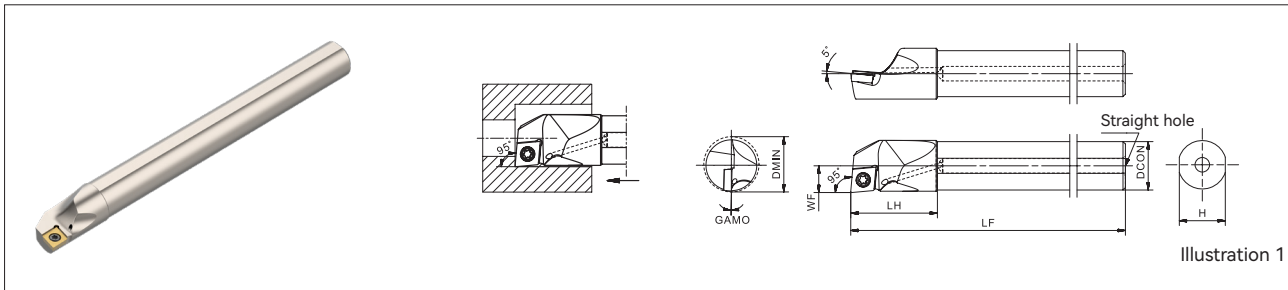

Product code	Stock		Minimum boring hole diameter (mm)	Dimension						Insert corner radius (RE)	Internal Coolant	Illustration	Spare parts		Insert
	R	L		DCON	H	LF	LH	WF	GAMO				Screw	Wrench	
			DMIN												
A10K-SCLPR/L08-12	○	○	12	10	9	125	20	6	5°	0.4	With	1	SP030065	FT-TP08	CP*T 0802...
A12M-SCLPR/L08-14	○	○	14	12	11	150	24	7	4°						
A16Q-SCLPR/L09-18	○	○	18	16	15	180	30	9	3.5°						
A20R-SCLPR/L09-22	○	○	22	20	19	200	36	11	2°				SP040093X	FT-TP15	CP*T 0903...
A25S-SCLPR/L09-27	○	○	27	25	24	250	46	13.5	0°						

● : Standard stock ○ : Made-to-Order

E-SCLP Carbide boring bar (Internal/Internal Face Boring)

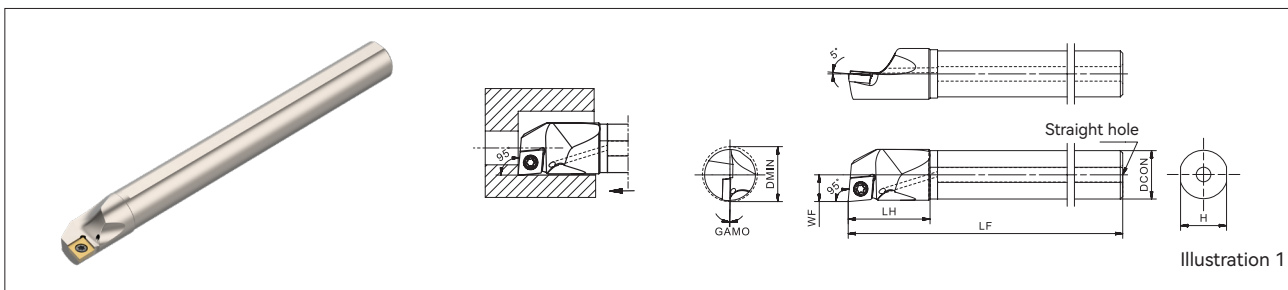

Product code	Stock		Minimum boring hole diameter (mm)	Dimension						Insert corner radius (RE)	Internal Coolant	Illustration	Spare parts		Insert
	R	L		DCON	H	LF	LH	WF	GAMO				Screw	Wrench	
			DMIN												
E10M-SCLPR/L08-12	○	○	12	10	9	150	18	6	5°	0.4	With	1	SP030065	FT-TP08	CP*T 0802...
E12M-SCLPR/L08-14	○	○	14	12	11	150	23	7	4°						
E16Q-SCLPR/L09-18	○	○	18	16	15	180	28	9	3.5°						
E20R-SCLPR/L09-22	○	○	22	20	19	200	32	11	2°				SP040093X	FT-TP15	CP*T 0903...
E25S-SCLPR/L09-27	○	○	27	25	24	250	38	13.5	0°						

● : Standard stock ○ : Made-to-Order

A-SDUC Steel boring bar (Internal/Internal Profile Boring)

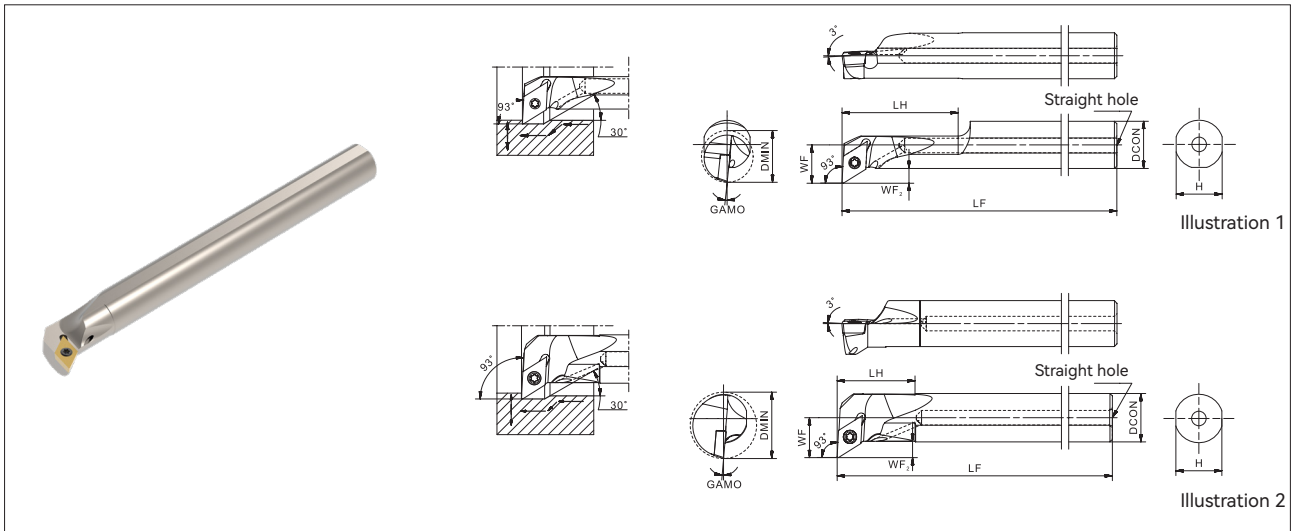

Product code	Stock		Minimum boring hole diameter (mm)	Dimension							Insert corner radius (RE)	Internal Coolant	Illustration	Spare parts		Insert
	R	L		DCON	H	LF	LH	WF	WF2	GAMO				Screw	Wrench	
A10K-SDUCR/L07-14	○	○	14	10	9	125	19	8.7	3.3	5°	0.4	With	2	SP025064	FT-TP08	DC*T 0702... DC*W 0702...
A16Q-SDUCR/L07-14	○	○		16	15	180	28	10.8	4.4							
A12M-SDUCR/L07-16	○	○	16	12	150	21	9.7	3.3	2							
A16Q-SDUCR/L07-20	●	●	20	16	15	180	27	11.3					3.5	1		
A20R-SDUCR/L11-20	●	●		20	19	200	53	15.6	6.1							
A16Q-SDUCR/L11-23	●	●	23	16	15	180	25.8	14.5	6.5				2			
A20R-SDUCR/L11-27	●	●	27	20	19	200	32.2	16.5						SP040065	FT-TP15	DC*T 11T3... DC*W11T3...
A25S-SDUCR/L11-32	●	●	32	25	24	250	36.9	19					SP040093X			

● : Standard stock ○ : Made-to-Order

E-SDUC Carbide boring bar (Internal/Internal Profile Boring)

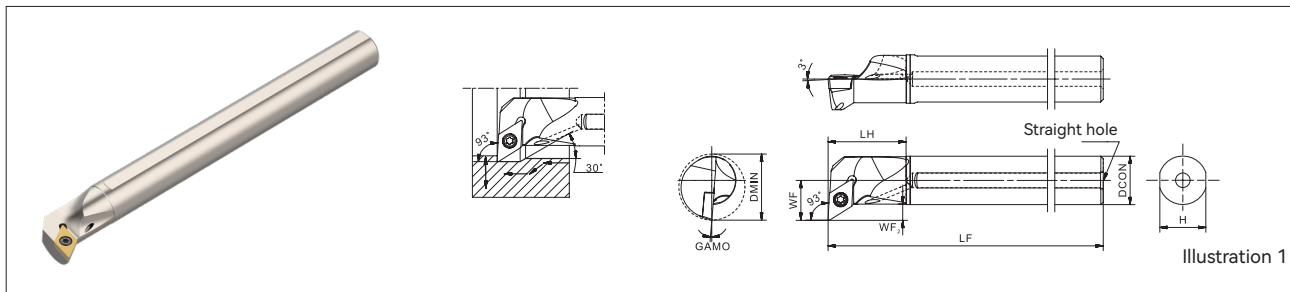

Product code	Stock		Minimum boring hole diameter (mm)	Dimension							Insert corner radius (RE)	Internal Coolant	Illustration	Spare parts		Insert			
	R	L		DCON	H	LF	LH	WF	WF2	GAMO				Screw	Wrench				
			DMIN																
E10M-SDUCR/L07-14	○	○	14	10	9	150	20	8.7	3.3	5°	0.4	With	1	SP025064	FT-TP08	DC*T 0702... DC*W 0702...			
E12M-SDUCR/L07-16	○	○	16	12	11	150	23	9.7											
E16Q-SDUCR/L07-20	○	○	20	16	15	180	28	11.7											
E16Q-SDUCR/L11-23	●	●	23	16	15	180	25.8	14.5	6.5					0.4	With	1	SP040065	FT-TP15	DC*T 11T3... DC*W11T3...
E20R-SDUCR/L11-27	●	●	27	20	19	200	32	16.5											
E25S-SDUCR/L11-32	○	○	32	25	24	250	38	19											

● : Standard stock ○ : Made-to-Order

A-SDQC Steel boring bar (Internal/Internal Profile Boring)

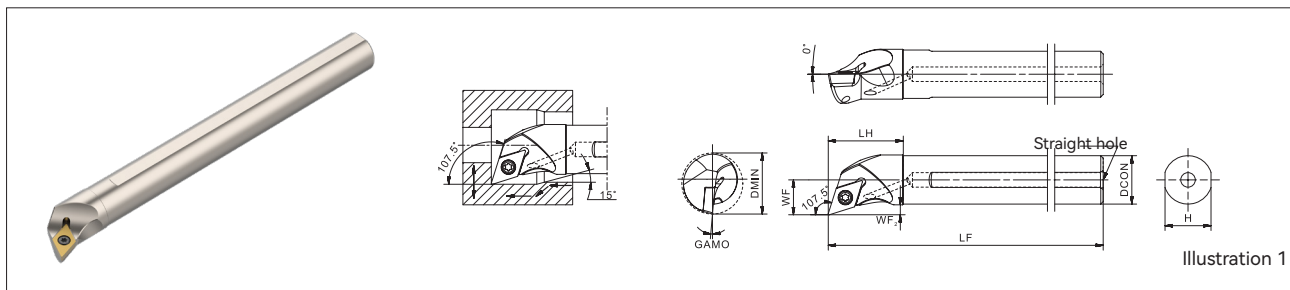

Product code	Stock		Minimum boring hole diameter (mm)	Dimension							Insert corner radius (RE)	Internal Coolant	Illustration	Spare parts		Insert
	R	L		DCON	H	LF	LH	WF	WF2	GAMO				Screw	Wrench	
			DMIN													
A10K-SDQCR/L07-13	○	○	13	10	9	125	19	7.5	2.1	10°	0.4	With	1	SP025064	FT-TP08	DC*T 0702... DC*W 0702...
A12M-SDQCR/L07-16	○	○	16	12	11	150	22	9.25	2.6	8°						
A16Q-SDQCR/L07-20	○	○	20	16	15	180	25	11.3	3.7	6°						
A20R-SDQCR/L11-25	●	●	25	20	19	200	31	14.4	3.7	5°				SP040065	FT-TP15	DC*T 11T3... DC*W11T3...
A25S-SDQCR/L11-30	○	○	30	25	24	250	38	16.9	4°	SP040093X						

● : Standard stock ○ : Made-to-Order

E-SDQC Carbide boring bar (Internal/Internal Profile Boring)

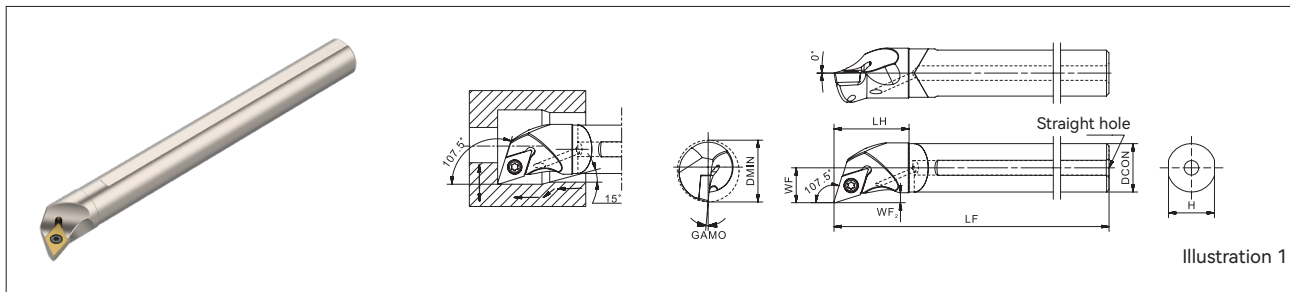

Product code	Stock		Minimum boring hole diameter (mm)	Dimension							Insert corner radius (RE)	Internal Coolant	Illustration	Spare parts		Insert
	R	L		DCON	H	LF	LH	WF	WF2	GAMO				Screw	Wrench	
			DMIN													
E10M-SDQCR/L07-13	○	○	13	10	9	150	20	7.5	2.1	10°	0.4	With	1	SP025064	FT-TP08	DC*T 0702... DC*W 0702...
E12M-SDQCR/L07-16	○	○	16	12	11	150	23	9.25	2.6	8°						
E16Q-SDQCR/L07-20	○	○	20	16	15	180	28	11.3	2.6	6°						
E20R-SDQCR/L11-25	●	●	25	20	19	200	31	14.4	3.7	5°						
E25S-SDQCR/L11-30	○	○	30	25	24	250	38	16.9	3.7	4°						

● : Standard stock ○ : Made-to-Order

A-STLC Steel boring bar (Internal/Internal Face Boring)

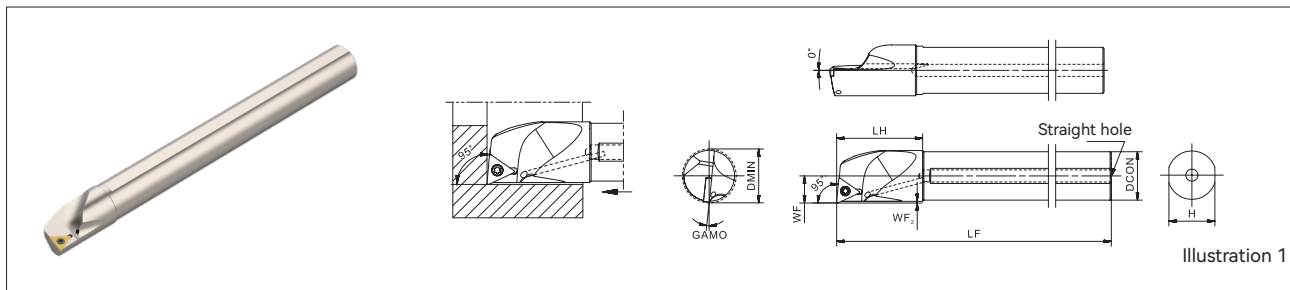

Product code	Stock		Minimum boring hole diameter (mm)	Dimension							Insert corner radius (RE)	Internal Coolant	Illustration	Spare parts		Insert
	R	L		DCON	H	LF	LH	WF	WF2	GAMO				Screw	Wrench	
			DMIN													
A08H-STLCR/L09-10	○	○	10	8	7	100	16	5	0.5	14°	0.4	With	1	SP022052	FT-TP07	TC*T 0902...
A10K-STLCR/L09-12	○	○	12	10	9	125	20	18.6	6.2	0.9						
A10K-STLCR/L11-12	●	●														
A12M-STLCR/L11-14	●	○	14	12	11	150	24	7.2	0.7	10°						
A16Q-STLCR/L11-18	○	○	18	16	15	180	30	9.2	0.7	8°						
A20R-STLCR/L11-22	●	●	22	20	19	200	36	11.2	0.7	6°						
A16Q-STLCR/L16-18	○	○	18	16	15	180	32	9.2	0.7	8°						
A20Q-STLCR/L16-22	○	○	22	20	18									11.2	6°	
A25R-STLCR/L16-27	○	○	27	25	23	200	46	13.7	0.7	4°						

● : Standard stock ○ : Made-to-Order

A-STLP Steel boring bar (Internal/Internal Face Boring)

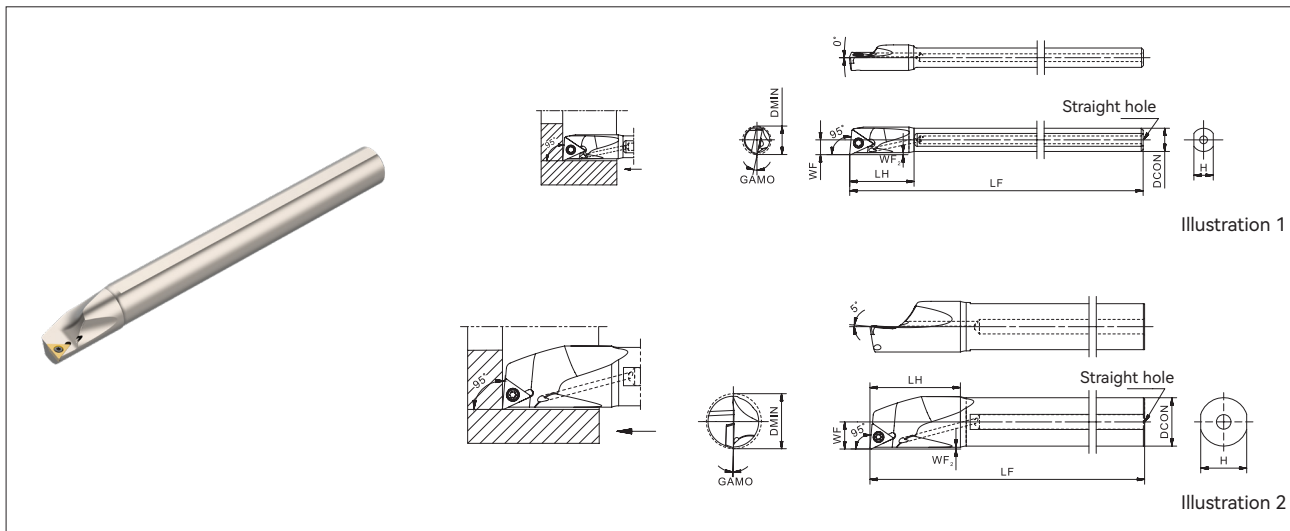

Product code	Stock		Minimum boring hole diameter (mm)	Dimension								Insert corner radius (RE)	Internal Coolant	Illustration	Spare parts		Insert			
	R	L		DCON	H	LF	LH	WF	WF2	GAMO	Screw				Wrench					
																DMIN				
A06F-STLBR/L06-08	●	●	8	6	5	80	15.3	3.8		12°	0.2	With	1	SP020035	FT-TP06	TB*T 0601...				
A08H-STLPR/L08-10	○	○	10	8	7	100	16	5	0.5	10°	0.4		2	2	SP022052	FT-TP07	TP*H 0802...			
A08H-STLPR/L09-10	○	○													SP025045	FT-TP08	TP*T 0902... TP*H 0902...			
A08H-STLPR/L09-10 (M2.2)	○	○													SP022052	FT-TP07				
A10K-STLPR/L09-12	●	●	12	10	9	125	25.7	6.2	0.9	8°	0.2		2	2	SP025045	FT-TP08	TP*T 1103... TP*H 1103...			
A10K-STLPR/L09-12 (M2.2)	●	○													SP022052	FT-TP07				
A10K-STLPR/L11-12	○	○													20	6	0.7	10°		
A12M-STLPR/L11-14	○	○	14	12	11	150	24	7.2	0.8	7°	0.4		2	2	SP030065	FT-TP08	TP*T 1103... TP*H 1103...			
A12M-STLPR/L09-16	○	○	16												8	0.6		5°	SP025045	FT-TP08
A12M-STLPR/L09-16 (M2.2)	○	○	SP022052												FT-TP07					
A16Q-STLPR/L11-18	●	●	18	16	15	180	30	9.2		3.5°	0.7		2	2	SP030065	FT-TP08	TP*T 1103... TP*H 1103...			
A20R-STLPR/L11-22	●	○	22	20	19	200	37.4	11.2		2°										
A25S-STLPR/L16-27	○	○	27	25	24	250	46	13.7		0°								2	2	SP040065

● : Standard stock ○ : Made-to-Order

E-STLP Carbide boring bar (Internal/Internal Face Boring)

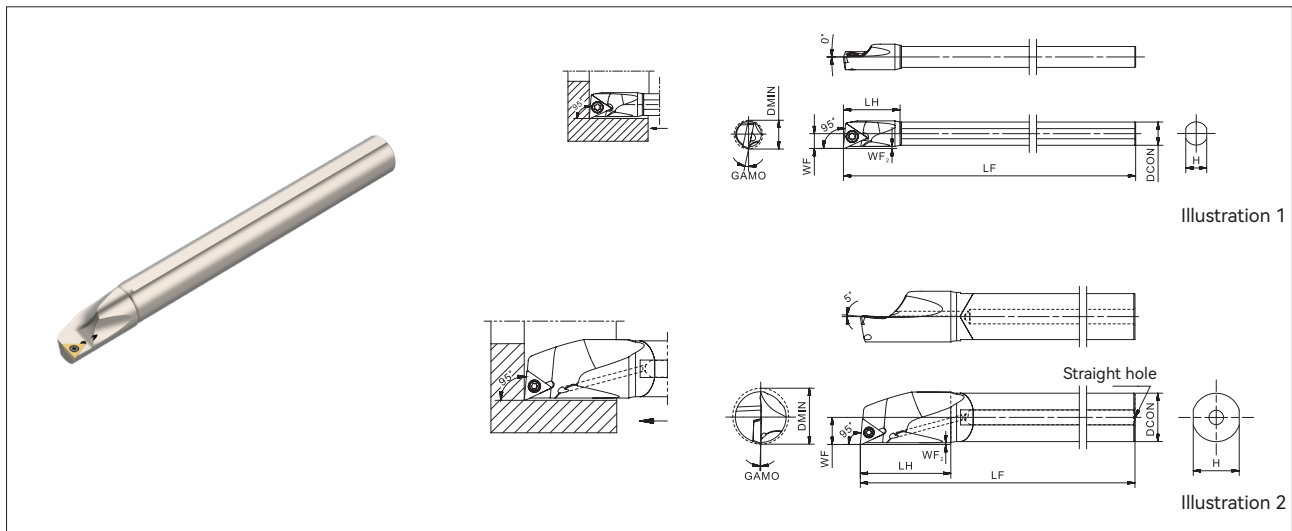

Product code	Stock		Minimum boring hole diameter (mm)	Dimension							Insert corner radius (RE)	Internal Coolant	Illustration	Spare parts		Insert					
	R	L		DCON	H	LF	LH	WF	WF2	GAMO				Screw	Wrench						
																	DMIN				
C06F-STLBR/L06-08	○	○	8	6	5.4	80	10	3.8	0.5	12°	0.2	Without	1	SP020035	FT-TP06	TB*T 0601...					
E08K-STLPR/L08-10	○	○	10	8	7	125	14	5	0.5	10°	0.4	With	2	SP022052	FT-TP07	TP*H 0802...					
E08K-STLPR/L09-10	○	○												100	150	6.2	0.9	8°	SP025045	FT-TP08	TP*T 0902... TP*H 0902...
E08H-STLPR/L09-10 (M2.2)	○	○																	SP022052	FT-TP07	
E10M-STLPR/L09-12	○	○	12	10	9	125	18	6	0.7	10°	0.4	With	2	SP025045	FT-TP08	TP*T 1103... TP*H 1103...					
E10K-STLPR/L09-12 (M2.2)	○	○												150	23		7.2	0.8	7°	SP022052	FT-TP07
E10M-STLPR/L11-12	○	○														SP030065				FT-TP08	
E12M-STLPR/L11-14	○	○	14	12	11	150	23	8	0.6	5°	0.4	With	2	SP025045	FT-TP08	TP*T 0902... TP*H 0902...					
E12M-STLPR/L09-16	○	○	16											SP022052			FT-TP07				
E12M-STLPR/L09-16 (M2.2)	○	○												SP030065	FT-TP08	TP*T 1103... TP*H 1103...					
E16Q-STLPR/L11-18	●	●	18	16	15	180	30	9.2	0.7	3.5°	0.4	With	2	SP030065	FT-TP08	TP*T 1103... TP*H 1103...					
E20R-STLPR/L11-22	●	○	22	20	19	200	37.5	11.2		2°											
E20R-STLPR/L16-25	○	○	25							32							13	0°			
E25S-STLPR/L16-27	○	○	27	25	24	250	38	13.7						SP040065	FT-TP15	TP*T 1603...					

● : Standard stock ○ : Made-to-Order

A-SVJC/B Steel boring bar (Internal Face/Internal Profile Boring)

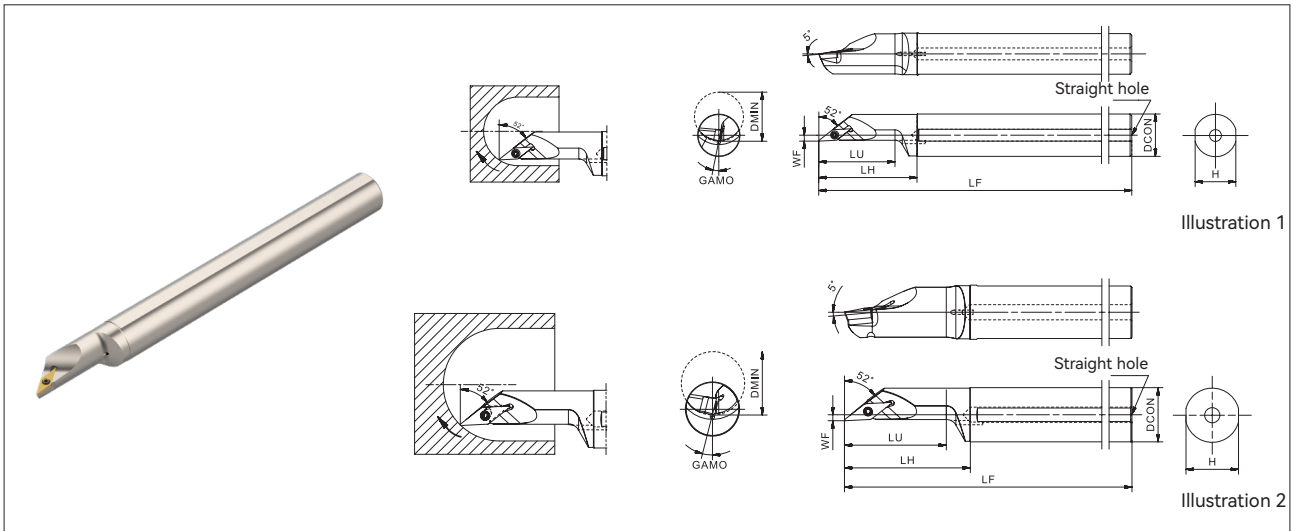

Product code	Stock		Minimum boring hole diameter (mm)	Dimension							Insert corner radius (RE)	Internal Coolant	Illustration	Spare parts					Insert
				DCON	H	LF	LU	LH	WF	GAMO				Shim	Shim screw	Wrench (Shim screw)	Screw	Wrench	
	R	L												DMIN					
A12M-SVJPR/L08-16	○	○	16	12	11	150	26	33	2	5°	0.2	With	1	-	-	-	SP020050	FT-TP06	VP*T 0802...
A12M-SVJCR/L08-16	○	○												-	-	-			
A16Q-SVJCR/L08-20	○	○	20	16	15	180	36	43	2	0.4	With	1	-	-	-	SP025064	FT-TP08	VB*T 1103...	
A20R-SVJBR/L11-25	○	○	25	20	19	200	37.5	48	2				-	-	-				-
A25S-SVJBR/L11-30	●	●	30	25	24	250	45	58	3.5	0.4	With	2	S-SVN16032	SH050084X	LT-H3.5	SP035120	FT-TP15	VB*T 1604...	
A32S-SVJBR/L16-40	○	○	40	32	31								60	74	8°	-	-	-	-
A40T-SVJBR/L16-50	○	○	50	40	39	300	75	91	4.5	7°	-	-	-	-	-	-	-	-	

● : Standard stock ○ : Made-to-Order

A-SVPP/B Steel boring bar (Internal Profile/Internal undercut Boring)

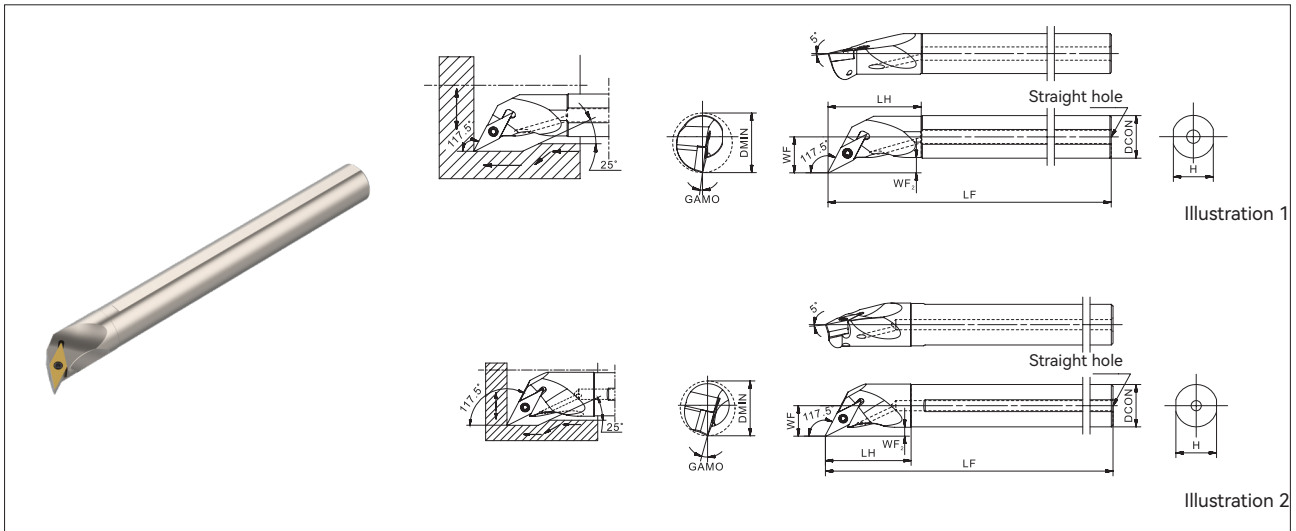

Product code	Stock		Minimum boring hole diameter (mm)	Dimension							Insert corner radius (RE)	Internal Coolant	Illustration	Spare parts					Insert	
				DCON	H	LF	LH	WF	WF2	GAMO				Shim	Shim screw	Wrench (Shim screw)	Screw	Wrench		
	R	L												DMIN						
A10K-SVPPR/L08-14	○	○	14	10	9	125	24	8.5	3	8°	0.4	With								
A12M-SVPBR/L11-18	○	○	18	12	11	150	29	11	4.5											
A16Q-SVPBR/L11-22	●	●	22	16	15	180	35	13.5	5.5	5°										
A20R-SVPBR/L11-26	○	○	26	20	19	200	41	15.5	5											
A25S-SVPBR/L16-31	○	○	31	25	24	250	51	18	5	13°										
A32S-SVPBR/L16-40	○	○	40	32	31		54	23	6.5	9°			2	S-SVN16032	SH050084X	LT-H3.5	SP035120	FT-TP15	VB*T 1604...	

● : Standard stock ○ : Made-to-Order

E-SVPP/B Carbide boring bar (Internal Profile/Internal undercut Boring)

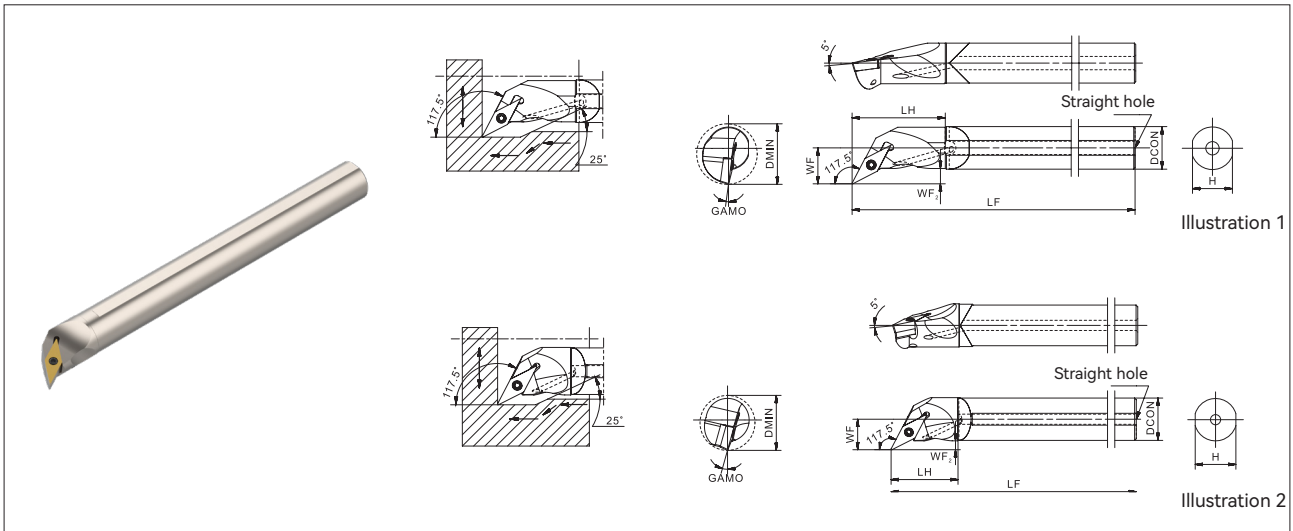

Product code	Stock		Minimum boring hole diameter (mm)	Dimension							Insert corner radius (RE)	Internal Coolant	Illustration	Spare parts					Insert						
	R	L		DCON	H	LF	LH	WF	WF2	GAMO				Shim	Shim screw	Wrench (Shim screw)	Screw	Wrench							
			DMIN																						
E10M-SVPPR/L08-14	○	○	14	10	9	150	21.5	8.5	3	8°	0.4	With	1						VP*T 0802...						
E12M-SVPBR/L11-18	○	○	18	12	11		23	11	4.5					-	-	-	-	-	-	-	-	-	-	-	
E16Q-SVPBR/L11-22	●	●	22	16	15	180	35	13.5	5.5	5°				0.4	With	1	-	-	-	SP025064	FT-TP08	VB*T 1103...			
E20R-SVPBR/L11-26	○	○	26	20	19	200	32	15.5	5								-	-	-				-	-	-
E25S-SVPBR/L16-31	○	○	31	25	24	250	38	18	5	13°							0.4	With	2	S-SVN16032	SH050084X	LT-H3.5	SP035120	FT-TP15	VB*T 1604...

● : Standard stock ○ : Made-to-Order

A-SVIP/B Steel boring bar (Internal Profile Boring)

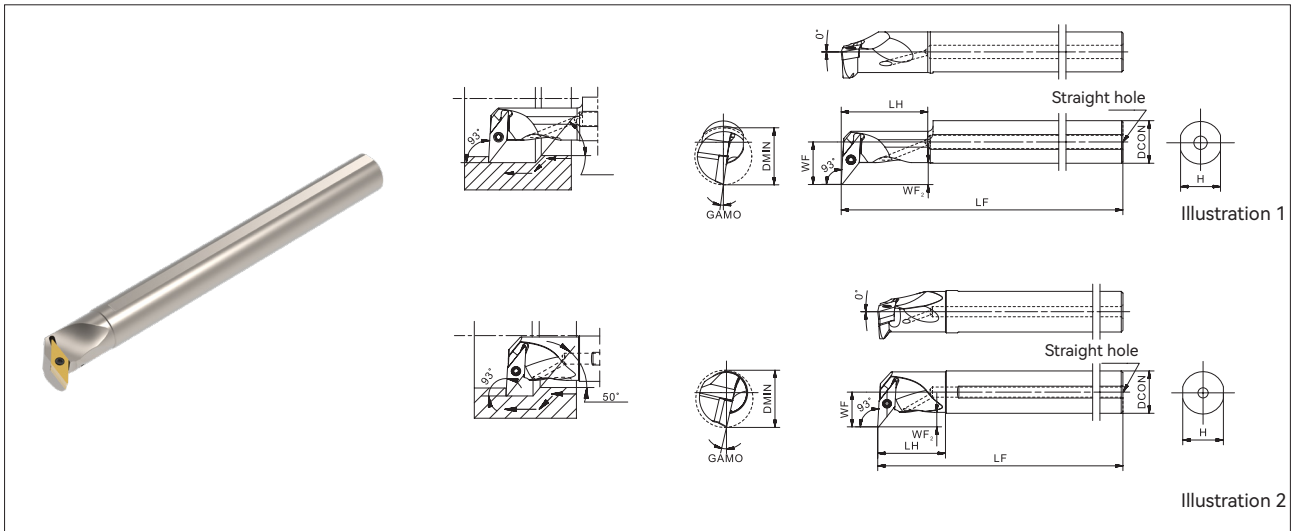

Product code	Stock		Minimum boring hole diameter (mm)	Dimension							Insert corner radius (RE)	Internal Coolant	Illustration	Spare parts					Insert	
	R	L		DCON	H	LF	LH	WF	WF2	GAMO				Shim	Shim screw	Wrench (Shim screw)	Screw	Wrench		
																				DMIN
A12M-SVUPR/L08-16	○	○	16	12	11	150	25.5	11.5	5.5	8°	0.4	With	1	-	-	-	SP020050	FT-TP06	VP*T 0802...	
A16Q-SVUBR/L11-20	●	●	20	16	15	180	32.5	16	8					7°	-	-	-	SP025064	FT-TP08	VB*T 1103...
A20R-SVUBR/L11-25	●	●	25	20	19	200	40.5	18		13°					2	S-SVN16032	SH050084X	LT-H3.5	SP035120	FT-TP15
A25S-SVUBR/L16-34	●	○	34	25	24	250	40	20.5	8.5					9°		-	-	-	-	-
A32S-SVUBR/L16-40	○	○	40	32	31	250	84	28	12											

● : Standard stock ○ : Made-to-Order

E-SVUP/B Carbide boring bar (Internal Profile Boring)

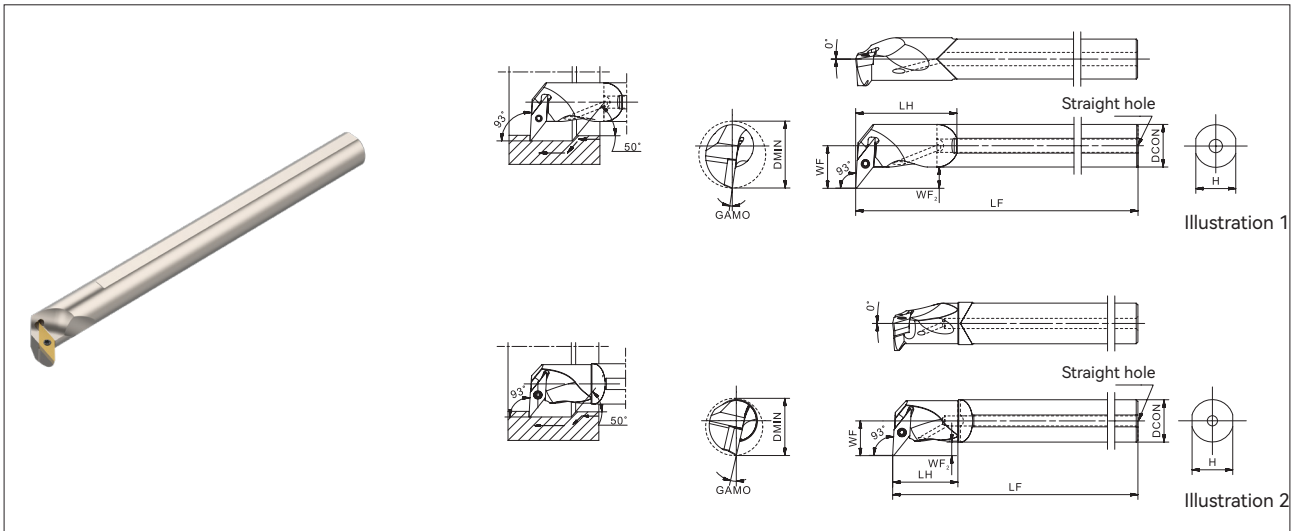

Product code	Stock		Minimum boring hole diameter (mm)	Dimension							Insert corner radius (RE)	Internal Coolant	Illustration	Spare parts					Insert
	R	L		DCON	H	LF	LH	WF	WF2	GAMO				Shim	Shim screw	Wrench (Shim screw)	Screw	Wrench	
			DMIN																
E12M-SVUPR/L08-18	○	○	18	12	11	150	23	11.5	5.5	8°	0.4	With	1						VP*T 0802...
E16Q-SVUBR/L11-25	●	●	25	16	15	180	28	16	8	8°				SP020050	FT-TP06	VP*T 1103...			
E20R-SVUBR/L11-29	○	○	29	20	19	200	32	18	7°	SP025064				FT-TP08	VB*T 1604...				
E25S-SVUBR/L16-34	●	○	34	25	24	250	38	20.5	8.5	13°				S-SVN16032	SH050084X	LT-H3.5	SP035120	FT-TP15	VB*T 1604...

● : Standard stock ○ : Made-to-Order

A-SWUB Steel boring bar (Internal Boring)

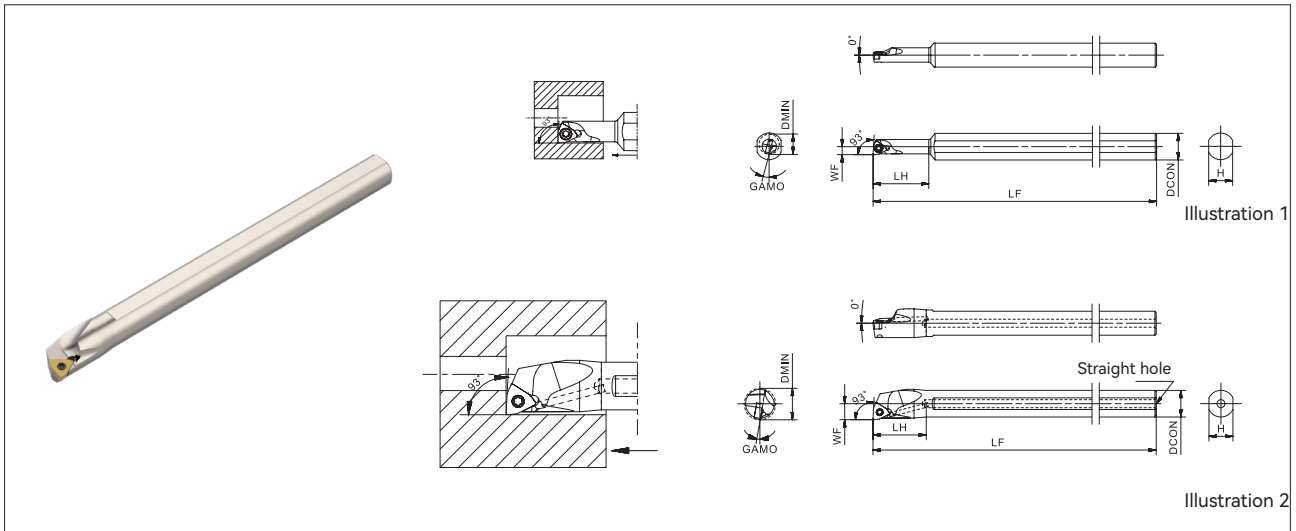

Product code	Stock		Minimum boring hole diameter (mm)	Dimension						Insert corner radius (RE)	Internal Coolant	Illustration	Screw	Wrench	Insert
	R	L		DCON	H	LF	LH	WF	GAMO						
			DMIN												
S10H-SWUBR/L06-06	●	●	6	10	9	100	21	3	15°	0.4	Without	1	SP020035	FT-TP06	WB*T 0601...
S10H-SWUBR/L06-07	○	○	7				25	3.5	13°						
S10H-SWUBR/L08-08	○	○	8				28	4	15°						
A08H-SWUBR/L08-10	○	○	10	8	7		16	5	13°	With	2	SP020050		WB*T 0802...	
A10K-SWUBR/L-08-12	●	●	12	10	9	125	20	6	10°						

● : Standard stock ○ : Made-to-Order

E-SWUB Carbide boring bar (Internal Boring)

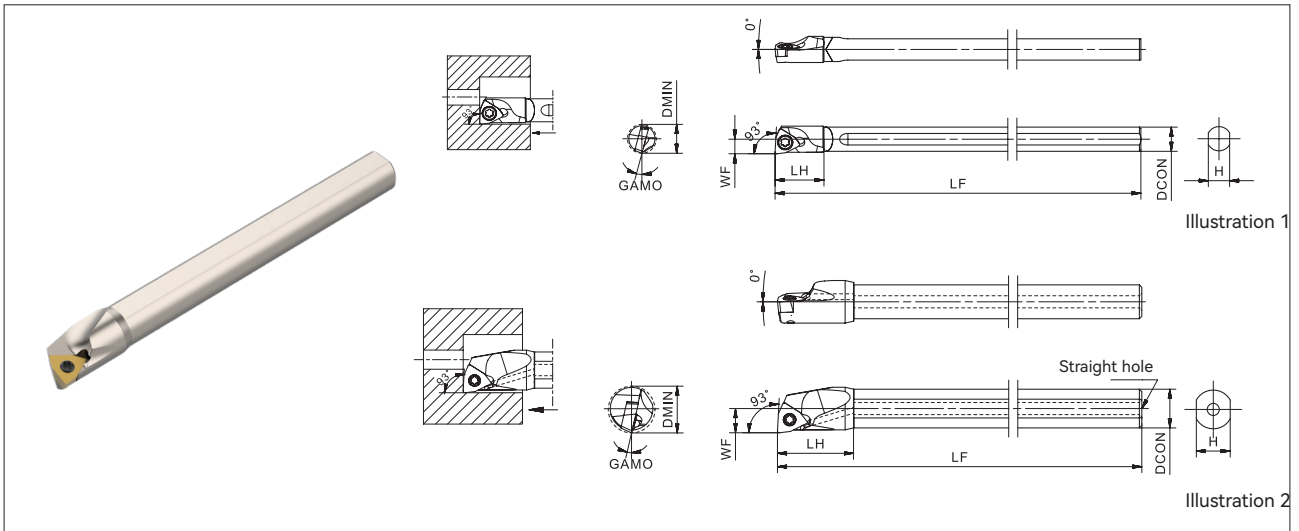

Product code	Stock		Minimum boring hole diameter (mm)	Dimension							Insert corner radius (RE)	Internal Coolant	Illustration	Screw		Wrench	Insert
	R	L		DCON	H	LF	LH	WF	GAMO	Screw				Wrench			
															DMIN		
C05G-SWUBR/L06-06	●	●	6	5	4.4	90	10	3	15°	0.4	Without	1	SP020035	FT-TP06	WB*T 0601...		
C06H-SWUBR/L06-07	○	○	7	6	5.4	100		3.5	13°							0.2	
C07J-SWUBR/L08-08	○	○	8	7	6.4	110	11	4	15°	0.4	With	2	SP020050	WB*T 0802...			
E08K-SWUBR/L08-10	●	●	10	8	7	125	14	5	13°								
E10M-SWUBR/L08-12	●	●	12	10	9	150	20	6	10°								

● : Standard stock ○ : Made-to-Order

A-DCLN steel boring bar (Internal/Internal Face Boring)

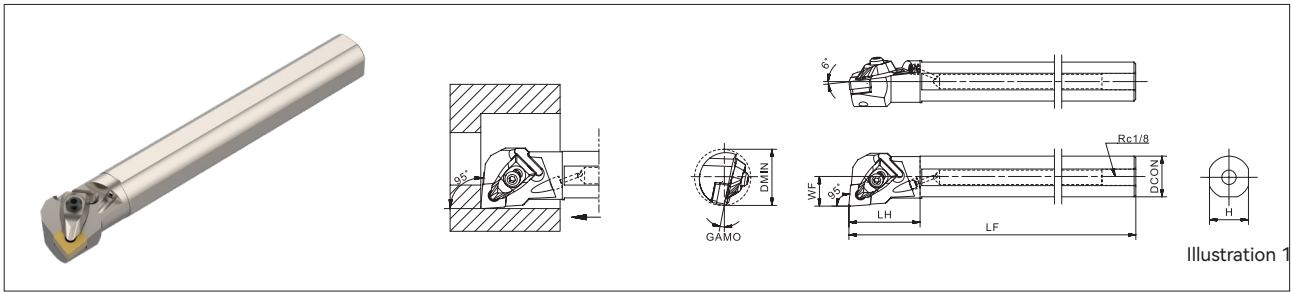

Product code	Stock		Minimum boring hole diameter (mm)	Dimension						Insert corner radius (RE)	Internal Coolant	Illustration	Spare parts							Insert
	R	L		DMIN	DCON	H	LF	LH	WF				GAMO	Wrench	Lever screw	Clamp	Spring	Shim	Shim screw	
A25R-DCLNR/L12-32	●	●	32	25	23	200	42	17	11°	0.8	With	1	LT-H3	CH 050215	CLD 255090	YB0.20-2.50-12-5.5	S-DCN 12032	SH 060080X	NZ 060020	CN*A 1204... CN*G 1204... CN*M 1204...
A32S-DCLNR/L12-40	●	●	40	32	30	250	50	22												
A40T-DCLNR/L12-50	○	○	50	40	37	300	60	27												

● : Standard stock ○ : Made-to-Order

S-PCLN steel boring bar (Internal/Internal Face Boring)

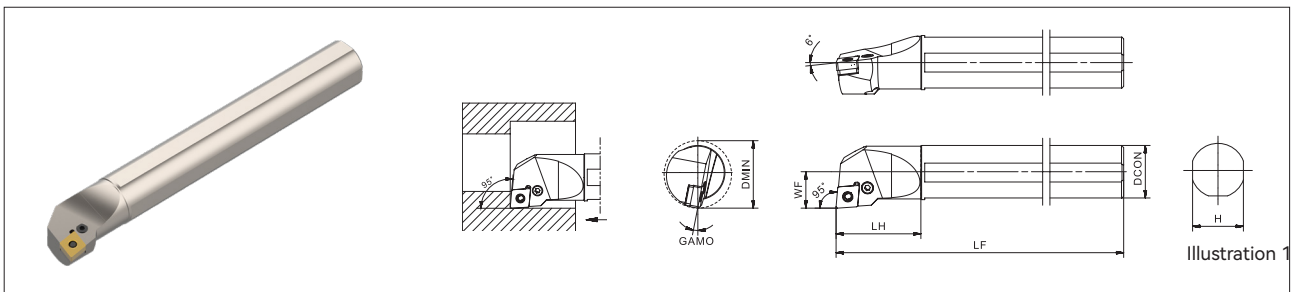

Product code	Stock		Minimum boring hole diameter (mm)	Dimension						Insert corner radius (RE)	Internal Coolant	Illustration	Spare parts					Insert
	R	L		DMIN	DCON	H	LF	LH	WF				GAMO	Wrench	Lever screw	Lever	Shim	
S25R-PCLNR/L12-32	○	○	32	25	24	200	42	16.3	10°	0.8	Without	1	LT-H3	LH080200	LV4C	S-PCN12032	SP4N	CN*A 1204... CN*G 1204... CN*M 1204...
S32S-PCLNR/L12-40	●	●	40	32	30	250	50	21										
S40T-PCLNR/L12-50	○	○	50	40	37	300	60	25										

● : Standard stock ○ : Made-to-Order

A-DDUN steel boring bar(Internal/Internal Profile Boring)

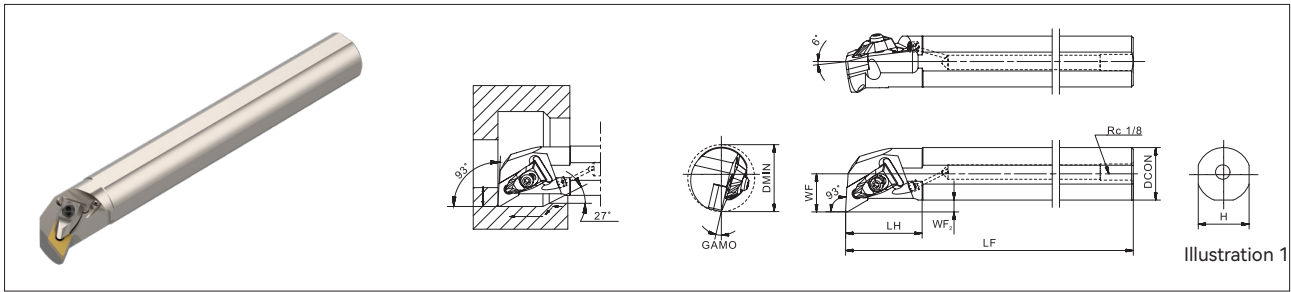

Product code	Stock		Minimum boring hole diameter (mm)	Dimension								Insert corner radius (RE)	Internal Coolant	Illustration	Spare parts							Insert
	R	L		DCON	H	LF	LH	WF	WF2	GAMO	Wrench				Lever screw	Clamp	Spring	Shim	Shim screw	Nozzle		
			DMIN																			
A32S-DDUNR/L15-40	●	●	40	32	30	250	45	22	8	13°	0.8	With	1	LT-H3	CH 050215	CLD 255090	YB0.20-2.50-12-5.5	S-DDN 15032	SH 060100X	NZ 060020	DN*A 1504... DN*G 1504... DN*M 1504...	
A40T-DDUNR/L15-50	○	○	50	40	37	300	55	27	8.5	12°												
A50U-DDUNR/L15-63	○	○	63	50	47	350	65	35	10.5													

● : Standard stock ○ : Made-to-Order

S-PDUN steel boring bar(Internal/Internal Profile Boring)

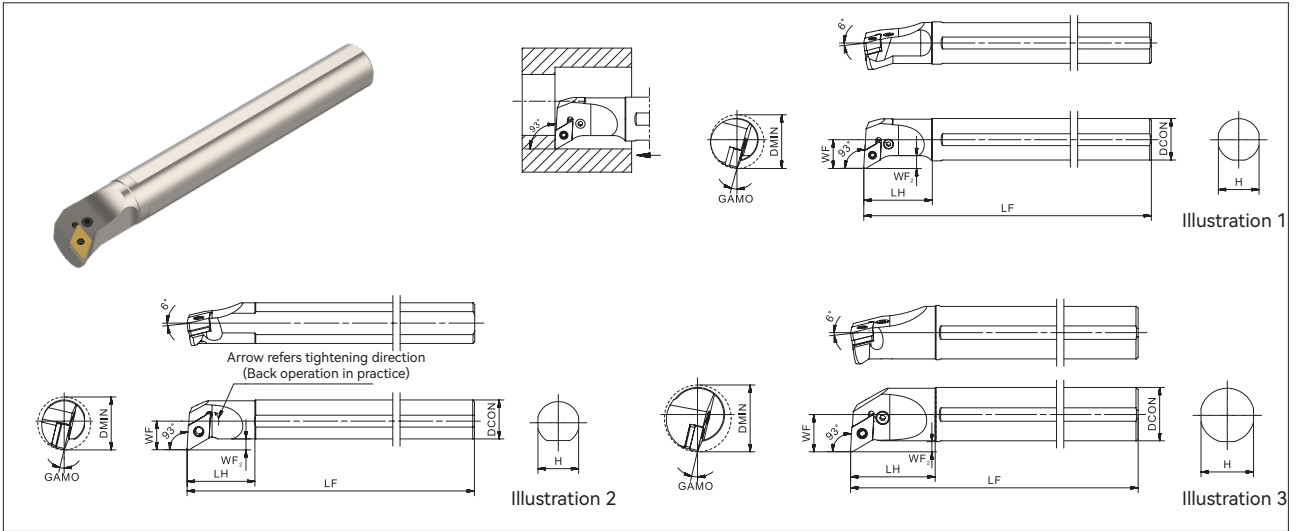

Product code	Stock		Minimum boring hole diameter (mm)	Dimension							Insert corner radius (RE)	Internal Coolant	Spare parts						Insert	
	R	L		DCON	H	LF	LH	WF	WF2	GAMO			Illustration	Wrench	Lever screw	Lever	Shim	Shim pin		Eccentric pin
S20Q-PDUNR/L11-27	○	○	27	20	19	180	35	16	17°	0.8	Without	1	LT-H2.5	LH060142	LV3	S-PDN11027	SP3	-	DN*G 1104...	
S25R-PDUNR/L11-32	○	○	32	25	24	200	40	17	7.6											15°
S32S-PDUNR/L11-40	○	○	40	32	31	250	45	22	8.5											12°
S25R-PDUNR/L15-32	○	○	32	25	24	200	40	17	6.5			13°	2	-	-	S-PDN15032X	-	EP046140	DN*A 1504... DN*G 1504... DN*M 1504...	
S32S-PDUNR/L15-44	○	○	44	32	31	250	50	22												
S40T-PDUNR/L15-54	○	○	54	40	39	300	65	27	7.5			12°								3

● : Standard stock ○ : Made-to-Order

S-PDQN steel boring bar(Internal/Internal Profile Boring)

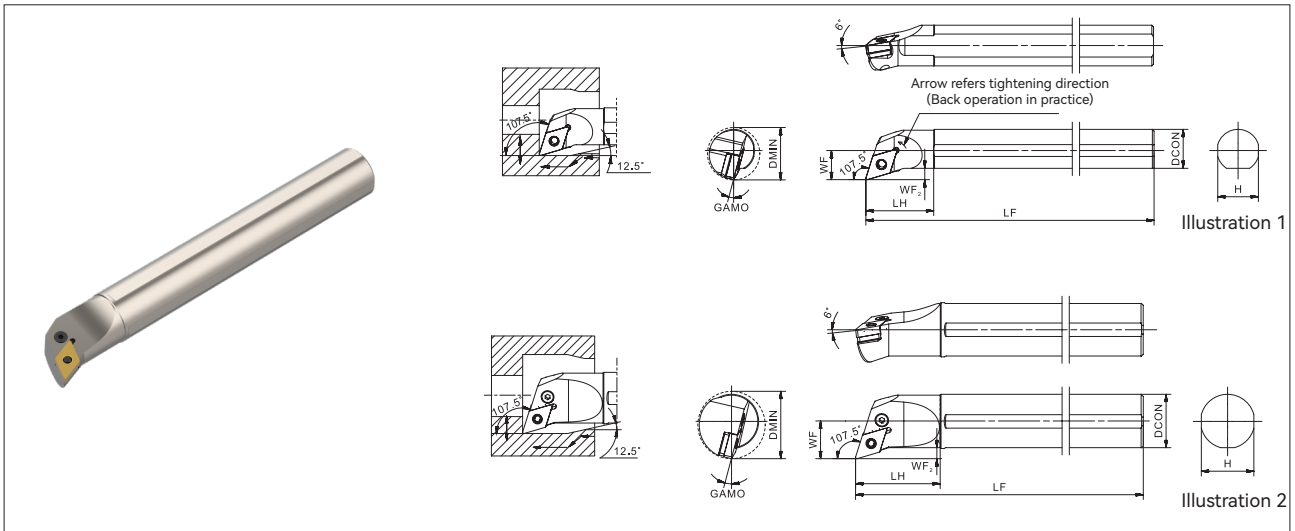

Product code	Stock		Minimum boring hole diameter (mm)	Dimension							Insert corner radius (RE)	Internal Coolant	Illustration	Spare parts					Insert	
	R	L		DMIN	DCON	H	LF	LH	WF	WF2				GAMO	Wrench	Lever screw	Lever	Shim		Shim pin
S25R-PDQNR/L15-32	○	○	32	25	24	200	40	17				Without	1	LT-H3	SP020050	-	S-PDN15032X	-	EP046140	DN*A 1504... DN*G 1504... DN*M 1504...
S32S-PDQNR/L15-44	○	○	44	32	31	250	50	22	6.5	13°	2				LH080200	LV4B	S-PDN15032	SP4N	-	
S40T-PDQNR/L15-54	○	○	54	40	39	300	65	27	7.5	12°										

● : Standard stock ○ : Made-to-Order

S-PDZN steel boring bar (Internal Back Boring)

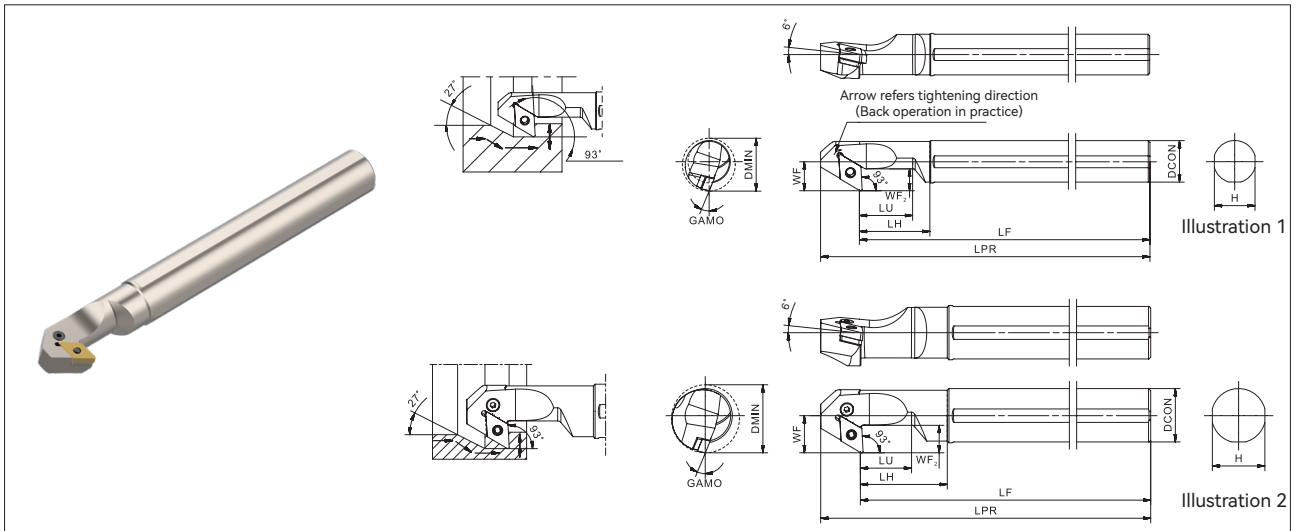

Product code	Stock		Minimum boring hole diameter (mm)	Dimension										Insert corner radius (RE)	Internal Coolant	Illustration	Spare parts						Insert
	R	L		DMIN	DCON	H	LPR	LF	LH	LU	WF	WF2	GAMO				GAMO	Lever screw	Lever	Shim	Shim pin	Eccentric pin	
S25R-PDZNR/L15-32	○	○	32	25	24	225	200	40	17	13			13°	Without	1								
S32S-PDZNR/L15-44	○	○	44	32	31	275	250	50	30	22			0.8			2	LT-H3	SP 020050	-	S-PDN 15032X	-	EP 046140	DN*A 1504... DN*G 1504... DN*M 1504...
S40T-PDZNR/L15-54	○	○	54	40	39	325	300	65	50	27	16	12°								LH 080200	LV4B	S-PDN 15032	

● : Standard stock ○ : Made-to-Order

A-DSKN steel boring bar(Internal Boring)

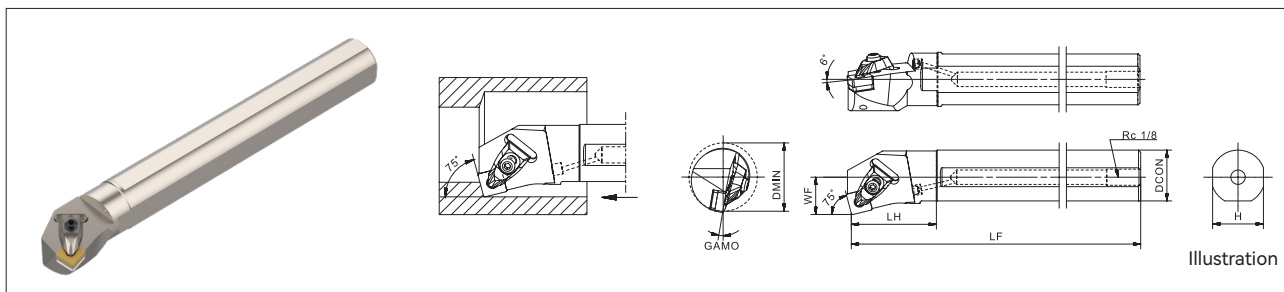

Product code	Stock		Minimum boring hole diameter (mm)	Dimension							Insert corner radius (RE)	Internal Coolant	Illustration	Spare parts							Insert
	R	L		DCON	H	LF	LH	WF	GAMO	Wrench				Lever screw	Clamp	Spring	Shim	Shim screw	Nozzle		
			DMIN																		
A25R-DSKNR/L12-32	○	○	32	25	23	200	43	17	11°	0.8	With	1	LT-H3	CH 050215	CLD 255090	YB0.20-2.50-12-5.5	S-DSN 12032	SH 060080X	NZ 060020	SN*A 1204... SN*G 1204... SN*M 1204...	
A32S-DSKNR/L12-40	○	○	40	32	30	250	43	22													
A40T-DSKNR/L12-50	○	○	50	40	37	300	53	27													NZ 100040

● : Standard stock ○ : Made-to-Order

A-DTFN steel boring bar(Internal Boring)

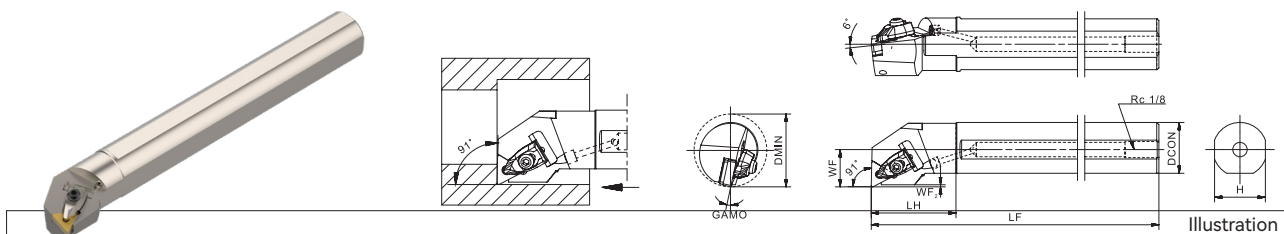

Product code	Stock		Minimum boring hole diameter (mm)	Dimension							Insert corner radius (RE)	Internal Coolant	Illustration	Spare parts							Insert
	R	L		DCON	H	LF	LH	WF	WF2	GAMO				Wrench	Lever screw	Clamp	Spring	Shim	Shim screw	Nozzle	
			DMIN																		
A25R-DTFNR/L16-32	○	○	32	25	23	200	42	17	0.8	12°	0.8	With	1	LT-H3	CH 050215	CLD 222075	YB0.20-2.50-12-5.5	S-DTN 16027	SH 050090X	NZ 060020	TN*A 1604... TN*G 1604... TN*M 1604...
A32S-DTFNR/L16-40	○	○	40	32	30	250	50	22	1.2												
A40T-DTFNR/L22-50	○	○	50	40	37	300	60	27	1.5												

● : Standard stock ○ : Made-to-Order

S-PTUN steel boring bar(Internal Boring)

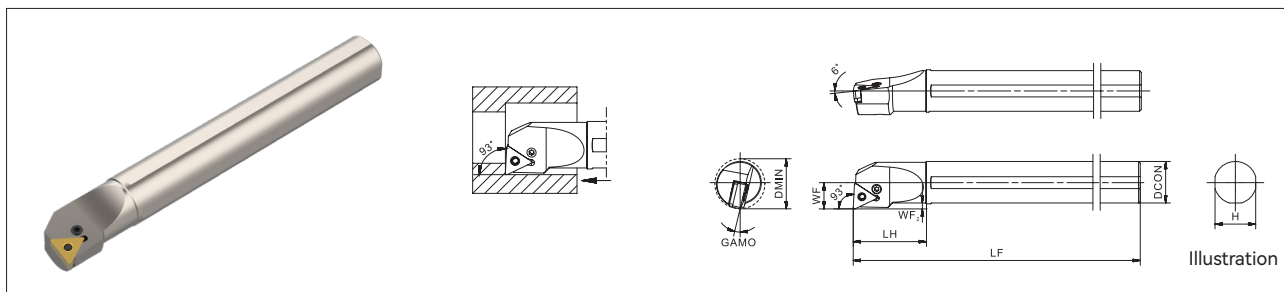

Product code	Stock		Minimum boring hole diameter (mm)	Dimension							Insert corner radius (RE)	Internal Coolant	Illustration	Spare parts					Insert
	R	L		DMIN	DCON	H	LF	LH	WF	WF2				GAMO	Wrench	Lever screw	Lever	Shim	
S32S-PTUNR/L16-40	○	○	40	32	30	250	50	22	0.7	13°	0.8	Without	1	LT-H2.5	LH060170	LV3	S-PTN16027	SP3	TN*A 1604... TN*G 1604... TN*M 1604...
S40T-PTUNR/L16-50	○	○	50	40	37	300	60	27	0.6	11°									

● : Standard stock ○ : Made-to-Order

A-DWLN steel boring bar(Internal/Internal Face Boring)

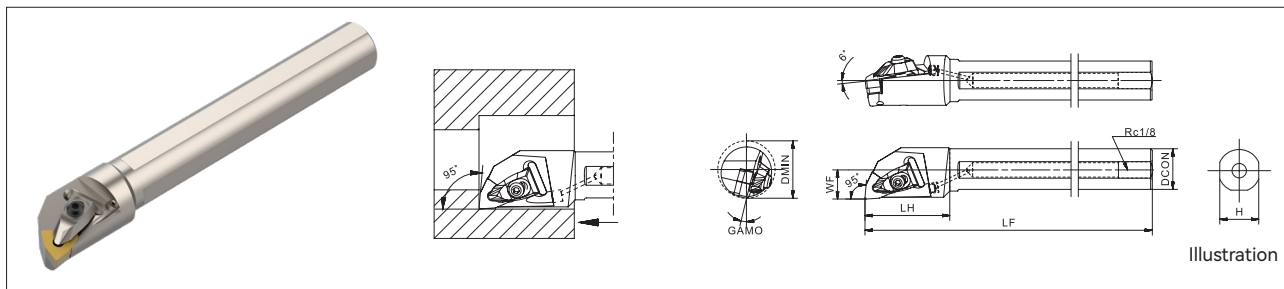

Product code	Stock		Minimum boring hole diameter (mm)	Dimension						Insert corner radius (RE)	Internal Coolant	Illustration	Spare parts							Insert	
	R	L		DMIN	DCON	H	LF	LH	WF				GAMO	Wrench	Lever screw	Clamp	Spring	Shim	Shim screw		Nozzle
A25R-DWLNLR/L08-32	●	●	32	25	23	200	50	17		13°	0.8	With	1	LT-H3	CH 050215	CLD 255090	YB0.20-2.50-12-5.5	S-DWN 08032	SH 060080X	NZ 060020	WN*A 0804... WN*G 0804... WN*M 0804...
A32S-DWLNLR/L08-40	○	○	40	32	30	250	50	22													
A40T-DWLNLR/L08-50	○	○	50	40	37	300	60	27						NZ 100040							

● : Standard stock ○ : Made-to-Order

S-PWLN steel boring bar(Internal/Internal Face Boring)

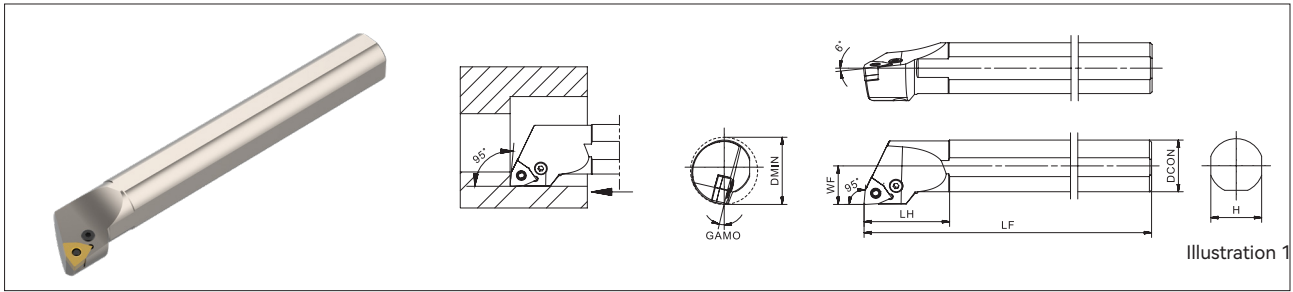

Product code	Stock		Minimum boring hole diameter (mm)	Dimension						Insert corner radius (RE)	Internal Coolant	Illustration	Spare parts					Insert
				DCON	H	LF	LH	WF	GAMO				Wrench	Lever screw	Lever	Shim	Shim pin	
	R	L	DMIN															
S16M-PWLN/L06-20	○	○	20	16	15	150	34	11	16°	0.8	Without	1						WN*G 0604...
S20Q-PWLN/L06-27	●	●	27	20	19	180	36.5	14.2	17°				LT-H2.5	LH060170	LV3	S-PWN06027	SP3	
S25R-PWLN/L06-32	○	○	32	25	24	200	42	15.7	15°									
S32S-PWLN/L08-40	○	○	40	32	30	250	50	22	10°									
S40T-PWLN/L08-50	○	○	50	40	37	300	60	27										

● : Standard stock ○ : Made-to-Order



GANZHOU ACHECK TOOL TECHNOLOGY CO.,LTD.

Add: Ganzhou Economic Development Area, Jiangxi, China
Tel: +86 797 8086879 E-mail: export@achtecktool.com